

通用小型铁氧体磁芯

GENERAL-PURPOSE SMALL FERRITE CORES

(Ni-Zn系列)

Ni-Zn FERITES

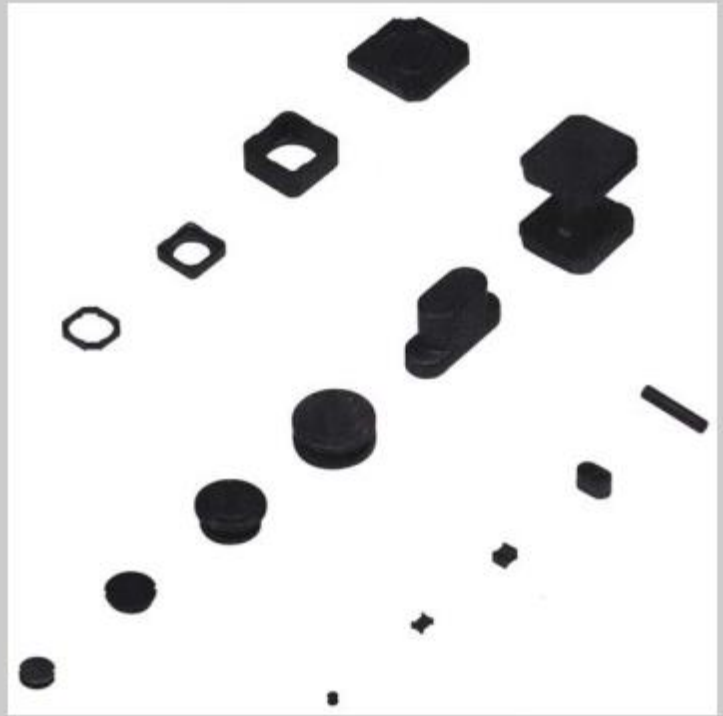

江苏磁元电子科技有限公司
JIANGSU CIYUAN ELECTRONICS TECHNOLOGY CO., LTD.

通用小型铁氧体磁芯介绍 An introduction to general-purpose ferrite cores

CIYUAN生产销售各种铁氧体磁芯，在这里介绍在电视机、VTR、收音机等AV机器回路中作为高频率线圈使用的通用铁氧体磁芯。

CIYUAN备有对应于伴随小型化、轻量化发展要求，高尺寸精度、高频率化的各种材质、形状的磁芯供您选择。

This catalog introduce CIYUAN general-purpose small cores used as high-frequency coils for televisions, VCRs, radios and other audio and visual equipment.

These small cores are highlighted by a super dimensional precision and high-frequency operation, in accordance with growing customer needs for smaller, lighter audio and visual equipment.

目录 Contents 页 Page

通用小型铁氧体磁芯介绍An introduction to general-purpose ferrite cores	1
Ni-Zn系材质Ni-Zn material series	2
主要产品Main products group	3
Ni-Zn铁氧体的用途Use of Ni-Zn ferrite cores	4
材质标准一览Standard material table	5
按用途推荐材质Recommendable material	6
1.功率电感器Power inductors	6
2.噪音滤波器用电感器Inductors for noise filter	8
3.耐模盘应力Mold stress-resistant material	9
4.孔型磁芯Balun cores	10
5.超高频(~ 1000MHz)用铁氧体磁芯A material for super wide frequency band	10
6.变压器用材料Materials for transformers	11
闭合磁路类功率电感用磁芯SMD type cores	12
工型磁芯Drum cores	22
柱型磁芯Rod cores	36
板条型磁芯Batten cores	37
帽型磁芯Pot cores	38
U型磁芯U type cores	39
矩型磁芯Square drum cores	40

关于Ni-Zn系材质 Ni-Zn MATERIAL SERIES

1. DL材(主用途: 工型磁芯, 帽型磁芯)

DL-materials(Main uses:Drum& Pot cores)

材质名的头上加 " DL " 的为High μ 材	Capital letter DL: High level μ
低频率滤波器 (LPF)	Low frequency filters(LPF)
低失真滤波器 (DAT,CD)	Low strain rate filters(DAT,CD)
IFT (BPF)	IFT(BPF)
电感器 (High L)	Inductors(High L)
功率电感器	Power inductors
DC- DC 转换器 (Power)	D/D converters

2. DK材(主用途: 工型磁芯, 环型磁芯)



DK-materials(Main uses: Drum& Ring cores)



材质名的头上加 " DK " 的为Middle μ 材	Capital letter DK: Middle level μ
VTR , 照相机滤波器	VTR ,Camera filters
扼流圈	Choke coils
电感器 (Middle L)	Inductors(Middle L)
平衡-不平衡变压器	Balun transformer
EMG 滤波器	EMG filters



3. DF材(主用途: 工型磁芯)

DF-materials(Main uses: Drum cores)

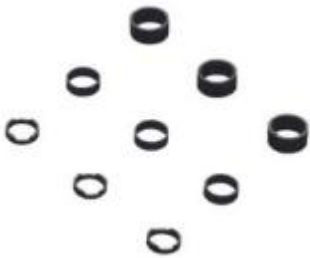
材质名的头上加 " DF " 的为Low μ 材	Capital letter DF: Low level μ
片式电感器	Chip inductors

产 品 Group	工型磁芯 Drum cores	矩型磁芯 Square drum cores	帽型磁芯 Pot cores
形状记录 Shape symbol	B	HB	LP, P
形状 Shape			

产 品 Group	环型磁芯 Ring(Sleeve) cores	矩型环状磁芯I Square ring cores I	矩型环状磁芯II Square ring cores II
形状记录 Shape symbol	FR	FRQ	FRD
形状 Shape			

产 品 Group	柱型磁芯 Rod cores	多孔磁芯 Multi-hole cores	双、四孔磁芯 Balun cores
形状记录 Shape symbol	R	PIC	TF
形状 Shape			

标准材质一览 STANDARD MATERIAL TABLE

应用部品 Application	主要形状 Types	使用回路 Circuits	实用机器 Equipment	材料主要特性 Characteristics of available materials	推荐材质 Recommendable materials
扼流圈 Choke coils (1)	筒状 Drum	AC/DC 变换回路 AC/DC converter DC-DC 转换器 DC-DC converter EL 回路 EL circuits 逆变回路 Inverter circuits	便携式电子机器 Portable equipment 音频器 Audio equipment	高通磁道率 High- μ 高磁通密度 High-B 低损耗 Low core loss	High- μ , High-B 材系列 High- μ High-B material series 低损耗材 Low core loss materials DL68,DL61,DL62,DL58, DL58H,DL46H,DL42H, DL35H,DL19H, DK41H
升压变压 (降压变压器) Step-up(Step-down) Transformers (1)	筒状 Drum	DC-DC 转换器 DC-DC converter EL 回路 EL circuits 断路器 Chopper 逆变器回路 Inverter circuits			
平衡-不平衡 变压器 Balun transformers	眼睛状 Balun 磁珠状 Bead	混频器回路 Mixer circuits 匹配电路 Matching circuits	音频器 Audio equipment 通信机 Communications equipment CATV	高电阻 High- ρ 低损耗 Low core loss	DK14,DL55
噪音滤波器 共态线圈 Noise filters common mode coils	UU 环状 Ring 磁珠状 Balun 眼睛状 Bead	EMI 对策回路 EMI prevention circuits 电源电缆 Power supply Cable 信号电缆 Signal Cable 传送回路 Transmission circuits	游戏 Game 通信机 Communication equipment OA 机器 OA equipment 测定器 Measurement equipment	宽带域 高阻抗 Wide-band impedance	DL68,DL59,DL61, DK32,DL51, DK26
片式电感器 Chip inductors	矩型 Square 筒状 Drum	高频率回路 High-frequency circuits 传送回路 Transmission circuits	音频器 Audio equipment 通信机 Communication equipment OA 机器 OA equipment	高 Q 值 High-Q 低损耗 Low core loss	抗应力材系列 Stress resistance material series DL52,DL39F,DL18F,DK17F, DK16F,DF15F,DF14F,DF11F
滤波器线圈 Filter coils	筒状 Drum	高频率回路 High-frequency	音频器 Audio equipment 通信机 Communication equipment	狭公差 Stress resistance free	抗应力材系列 Stress resistance material series
天线线圈 Antenna coils	柱状 Rod	通信机 Communication equipment AM SW FM	音频器 Audio equipment 载波器 Security equipment 通信机 Communication equipment 汽车用电子锁 Keyless key for car use	高 Q 值 High-Q	DK32,DK14,DF15F,DF11F
电波吸收体 Electromagnetic absorbers	粉末板 Powder Sheet	屏蔽材 Shield materials 高频率回路 High-frequency circuits	测定器 Measurement equipment 通信机 Communication equipment	高阻抗 High-impedance	NB 系列 NB series
IFT VCO	筒状 Drum	调协 Tuners 发信回路 Transmission circuits	音频器 Audio equipment 通信机 Communication equipment	高 Q 值 High-Q 温度特性 Superior temperature characteristics	高频率材系列 High-frequency material series
延迟线 Delay lines	筒状 Drum	数字回路的测试调整 Timing adjustment for digital circuits	计算机 Computer OA 机器 OA equipment		DK14,DK26,DG10
线性线圈 Linearity coils	筒状 Drum	画面失真校正回路 Convergence adjustment circuits	电视机 TV 显示器 Display 电炉	高饱和磁通密度 High-B	DL51,DK34,DL42H
升压变压器(2) Step-up transformers	柱状 Rod	点火装置(点火器) Igniter	Fan heater 锅炉 Boiler	高饱和磁通密度 High-B	DL51,DK34,DL19H
升压变压器(3) Step-up transformers	柱状 Rod	升压回路 Step-up circuits	车载用顶灯 Head light for car use	高饱和磁通密度 High-B	DK34,DL19H
扼流圈(2) Choke coils	柱状 Rod	磁控管 Magnetron	微波炉 Microwave ovens	高饱和磁通密度 High-B	DL51,DL19H

标准材质一览 STANDARD MATERIAL TABLE

材质名 Material names		特 性 Characteristics							
		初始磁导率 Permeability	相对损耗因数 Relative loss factor		饱和磁通密度 Flux dens	温度系数 Temp.factor	居里温度 Curie temp	适用频率 Effective freq	电阻率 Electrical resistivity
		μ_{ic}	$\tan\delta/\mu_i$		Bms	$\alpha_{\mu r}$	Tc	f	ρ
单位 Unit	-----	[$\times 10^{-5}$]	[MHz]	[mT]	[$\times 10^{-6}$]	[°C]	[MHz]	[$\Omega \cdot m$]	
DL68	2,000	3.0	0.2	270	2	>110	0.01~0.3	10 ⁶	
DL62	1,400	4.0	0.2	345	3~5	>125	0.01~0.3	10 ⁶	
DL59	1,350	1.1	0.4	285	2	>100	0.01~0.3	10 ⁶	
DL61	1,300	2.0	0.2	350	5	>135	0.01~0.3	10 ⁶	
DL59A	1,000	2.8	0.4	290	1~4	>100	0.01~0.7	10 ⁶	
DL55	1,000	2.1	0.4	270	2	>115	0.01~0.7	10 ⁶	
DL58	750	1.8	0.4	350	8	>170	0.01~0.8	10 ⁶	
DL47H	750	2.0	0.4	425	3	>180	0.1~0.8	10 ⁶	
DL46H	700	2.0	0.4	440	9~12	>180	0.1~1	10 ⁶	
DK32	700	1.7	0.4	300	7	>140	0.01~0.8	10 ⁶	
DL52	700	1.5	0.5	300	3	>130	0.1~1	10 ⁶	
DL42H	600	2.0	0.4	445	9	>200	0.1~1	10 ⁶	
DL31	600	1.5	0.4	280	7	>170	0.1~2	10 ⁶	
DL35H	550	2.5	0.4	380	10	>180	0.1~2	10 ⁶	
DL58H	500	3.0	0.4	400	4~12	>200	0.1~2	10 ⁶	
DL39F	500	3.0	0.4	340	2~6	>140	0.1~1.5	10 ⁶	
DK34	450	1.8	0.4	390	14	>160	0.1~3	10 ⁶	
DL51	350	1.5	0.5	340	20	>200	0.1~2	10 ⁶	
DL19H	280	2.8	0.6	450	15	>200	0.3~5	10 ⁶	
DL18F	200	3.7	1.0	320	0~5	>200	0.3~5	10 ⁶	
DK41N	200	8.0	1.0	250	-3~3	>100	0.1~5	10 ⁶	
DK41H	200	4.0	1.0	420	20~40	>300	0.1~5	10 ⁶	
DK14	100	5.5	1.0	360	10	>300	0.3~8	10 ⁶	
DK17	100	5.0	1.0	280	8	>300	0.1~8	10 ⁶	
DK17F	100	5.0	1.0	280	5~8	>300	0.1~8	10 ⁶	
DK16F	70	8.0	1.0	310	5~10	>300	1~10	10 ⁶	
DK26	40	15.0	10.0	350	10~20	>300	0.1~30	10 ⁶	
DF70	40	11.0	1.0	240	40	>300	1~20	10 ⁶	
DF15F	40	13.0	2.0	200	-10~5	>300	1~20	10 ⁶	
DF14F	20	27.0	10.0	200	-10~5	>300	3~30	10 ⁶	
DF11F	6	210.0	20.0	230	30	>300	10~200	10 ⁶	
DG10	1	*因为是反强磁性,所以去除了特性的记载. Characteristics are left out,because this material is anti ferromagnetic							

注：上述值为室温在20°C±5°C条件下，环形磁芯(FR25Ø/15Ø/5)的标准特性。
所有材料的特性为该材料的参考值，实际材料可能稍有不同。

按用途推荐材质 RECOMMENDABLE MATERIALS

1. 功率电感器 Power inductors

对于电源用扼流圈、线性线圈，DC-DC转换器线圈用变压器、不汇聚补正线圈，和其他表面安装型电感器非常适合。

High-B material of CIYUAN are most suitable to chock coils for power supply ,DC-DC converter,coils for transformer, mis-convergence correct coils and SMD type inductor.

材质名 Material	单位 Unit	μ ---	$\tan\delta/\mu$ [$\times 10^{-5}$]	Bms [mT]	Hc [A/m]	α_{pr} [$\times 10^{-6}$]	Tc [$^{\circ}\text{C}$]	备注 Remarks
DL58		750	1.8(0.4MHz)	350	35	8	>170	
DL46H		700	2.0(0.4MHz)	440	40	9~12	>180	
DL42H		600	2.0(0.4MHz)	445	42	9	>200	
DL35H		550	2.5(0.4MHz)	380	40	10	>180	耐热冲击材 Heat-resistant
DL58H		500	3.0(0.4MHz)	400	40	4~12	>200	
DL51		350	1.5(0.5MHz)	340	40	20	>200	
DL19H		280	2.8(0.6MHz)	450	64	15	>200	
DK41H		200	4.0(1.0MHz)	420	70	20~40	>300	耐热冲击材 Heat-resistant

● 实形状特性 Characteristics in actual shapes

B150130 DC-Bias 曲线 curves

$\phi 0.55$ 2-UEW 47.5[turns]

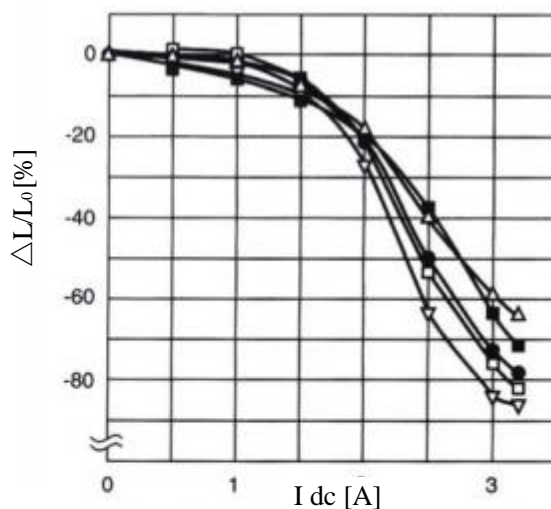
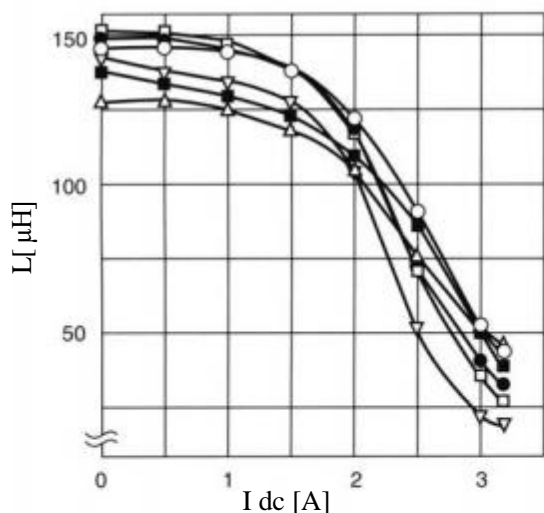

- L46H
- L42H
- ▽ L51
- L19H
- △ K41H
- L33H

形状 Actual

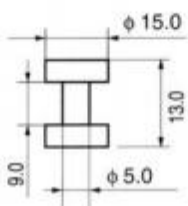

电容器 Capacitor
22000[μF]

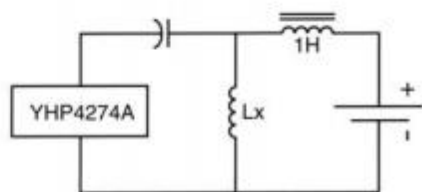

直流 DC
电流 source

• B—H特性 B—H curves

DL42H, DL35H B~H曲线

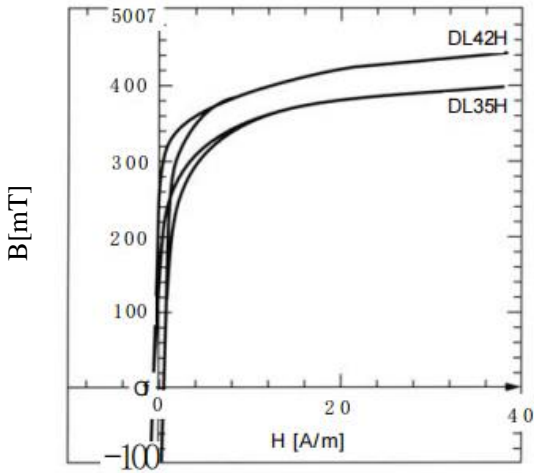

DK41H, DL19H B~H曲线

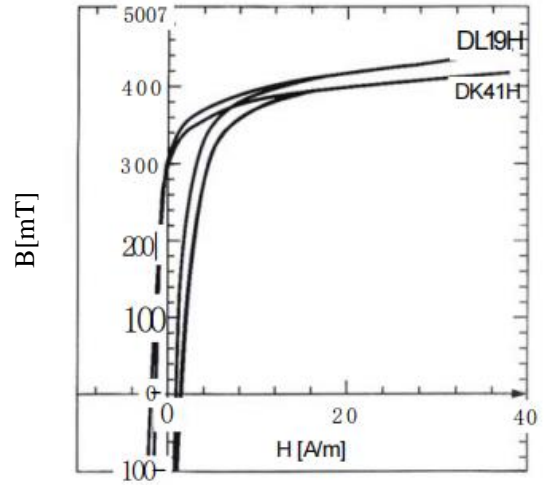

DL58, DL58H B~H曲线

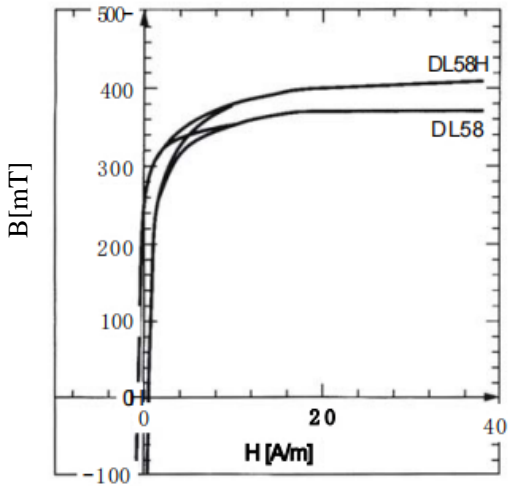

DL46H, DL51 B~H曲线

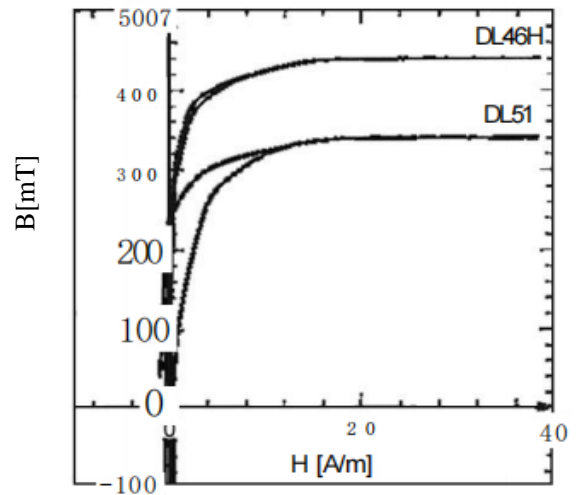

• μ' 及 μ'' 的频率特性 Frequency vs μ' , μ''

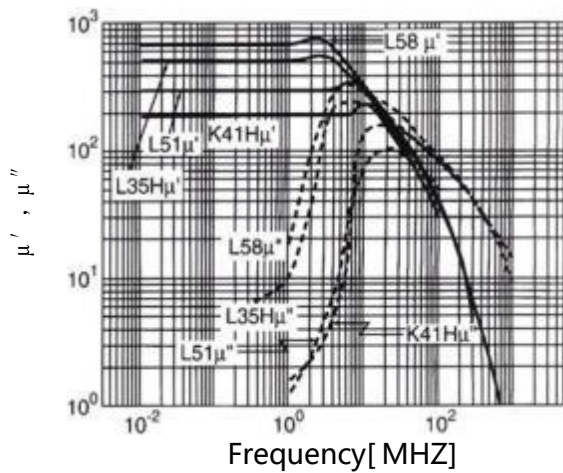
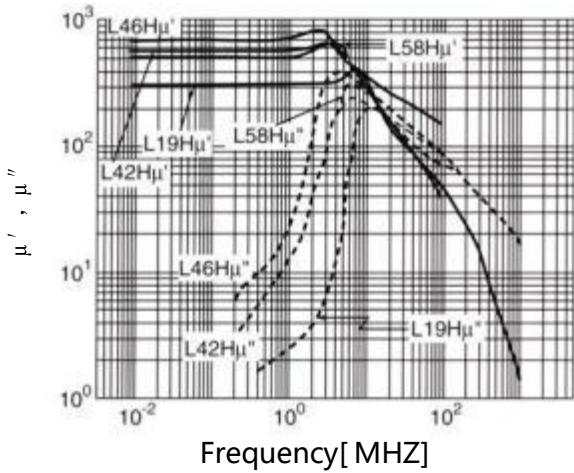

2. 噪音滤波器用电感器 Inductors for noise filter

作为数据传输不要辐射的对策，最为有效。

Following materials are most effective for considering to differential mode noise in data line.

材质名 Material	单位 Unit	μ_{iac} ---	$\tan\delta/\mu i$ [$\times 10^{-5}$]	Bms [mT]	Hc [A/m]	$\alpha_{\mu r}$ [$\times 10^{-6}$]	Tc [$^{\circ}C$]	备注 Remarks
DK32		700	1.7(0.4MHz)	300	40	7	>140	宽带域特性 wide freq.band
DL51		350	1.5(0.5MHz)	340	40	20	>200	
DK14		100	5.5(1.0MHz)	360	318	10	>300	
DK26		40	15(10.0MHz)	350	750	10~20	>300	

● μ' 及 μ'' 的频率特性

Frequency characteristic of μ' & μ''

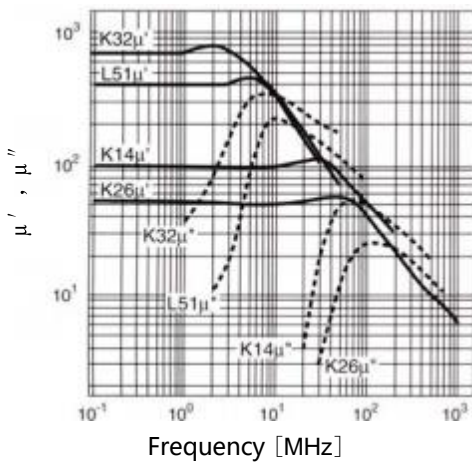

● |Z&|: 材质阻抗的频率特性

Material impedance [Ω/cm]

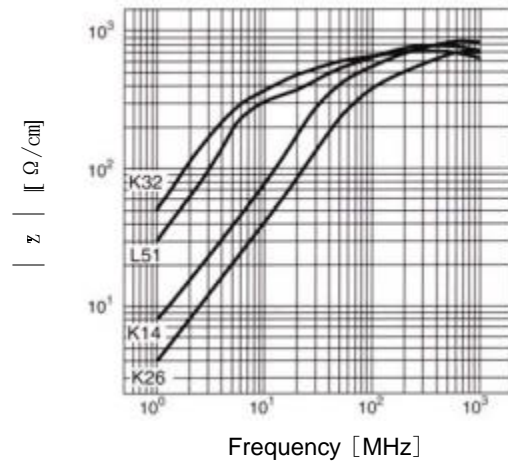

磁芯的阻抗|Z|和材质阻抗|Z&|有以下的关系:

The impedance of a core can be calculated by the following expression:

$$|Z| = \frac{A_e}{L_e} \cdot N^2 \cdot |Z\&|$$

|Z&| : 材质的阻抗
material impedance

|Z| : 磁芯的阻抗
the impedance of a core

Ae : 磁芯的平均横断面积
average sectional area of a core

Le : 磁芯的平均磁路长
average magnetic path length of a core

N : 线圈匝数
winding turn

3. 耐模盘应力 Mold stress-resistant materials

对于代表片式电感器的树脂模型产品最为有合适。
能够充实系列，提高材料的可选性。

Following material are most suitable to resin molder cores like chip inductors.

材质名 Material	单位 Unit	μ_{ac} ---	$\tan\delta/\mu_i$ [$\times 10^{-5}$]	Bms [mT]	Hc [A/m]	$\alpha_{\mu r}$ [$\times 10^{-6}$]	Tc [$^{\circ}C$]	备注 Remark
DL52		700	1.5(0.4MHz)	300	46	3	>130	
DL39F		500	3.0(0.4MHz)	340	52	2~6	>140	
DL18F		200	3.7(1.0MHz)	320	126	0~5	>200	
DK17F		100	5.0(1.0MHz)	280	301	5~8	>300	
DK16F		70	8(1.0MHz)	310	-	5~10	>300	
DF15F		40	13(2.0MHz)	200	-	-10~5	>300	
DF14		20	27(10MHz)	200	-	-10~5	>300	
DF11F		6.5	210(20MHz)	230	-	20~40	>300	

● 根据静荷重、感应系数的变化 The relation between force & inductance

$\Delta L/L_0[\%]$

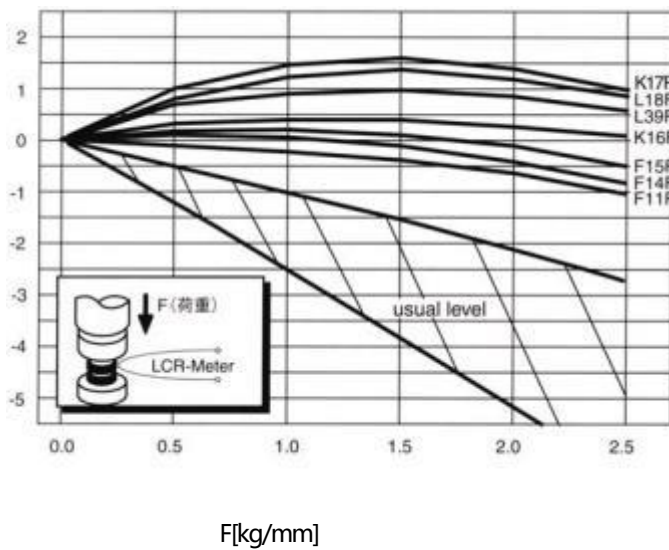

● μ' 及 μ'' 的频率特性
Frequency vs μ' , μ''

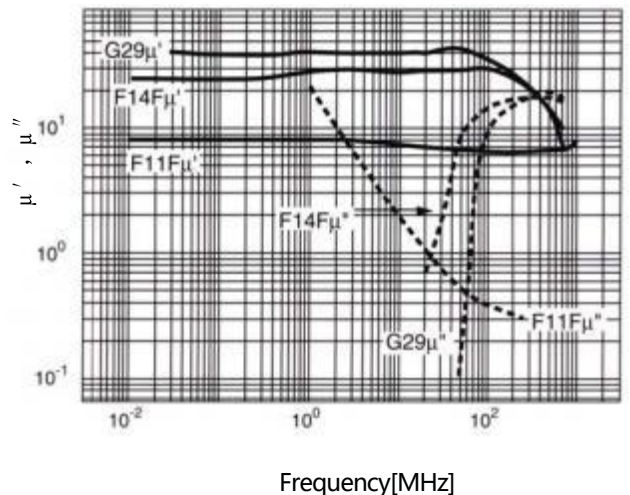
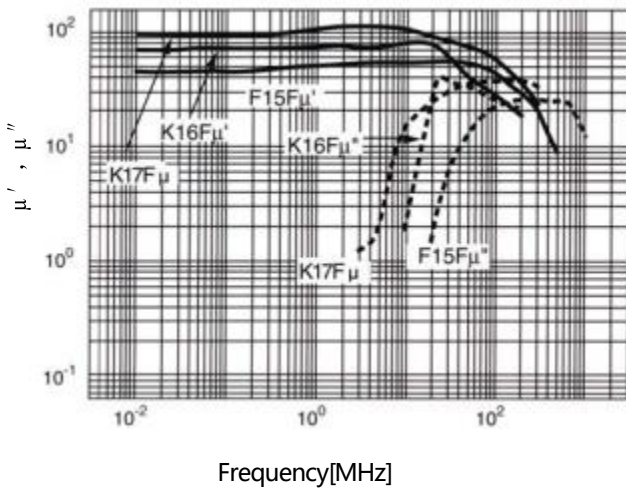
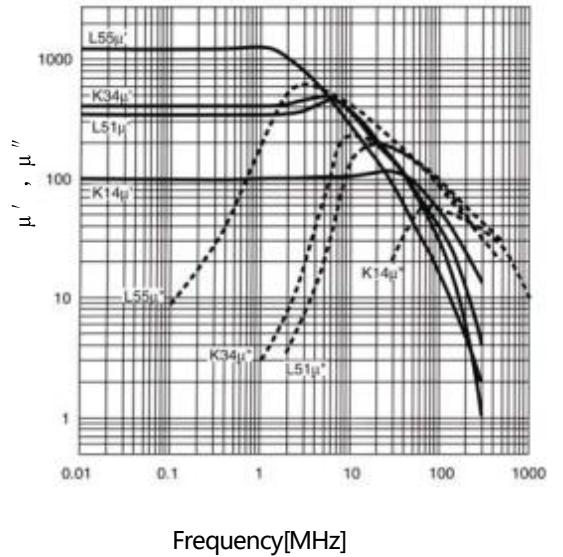

按用途推荐材质 RECOMMENDABLE MATERIALS

4. 孔型磁芯 Balun cores

作为匹配电路、配电器、混和器，还有平衡混频器用最为适合。

Following materials are most suitable to matching transformers, baluns and balanced mixers.

材质名 Material	单位 Unit	μ —	$\tan\delta/\mu$ [$\times 10^{-5}$]	Bms [mT]	α_{ur} [$\times 10^{-6}$]	Tc [$^{\circ}\text{C}$]
DL55		1000	2.1(0.4MHz)	270	2	>115
DK34		400	1.8(0.4MHz)	390	14	>160
DL51		350	1.5(0.5MHz)	340	20	>200
DK14		100	5.5(1.0MHz)	360	10	>300

● μ' 及 μ'' 的频率特性 Frequency characteristic of μ' & μ''

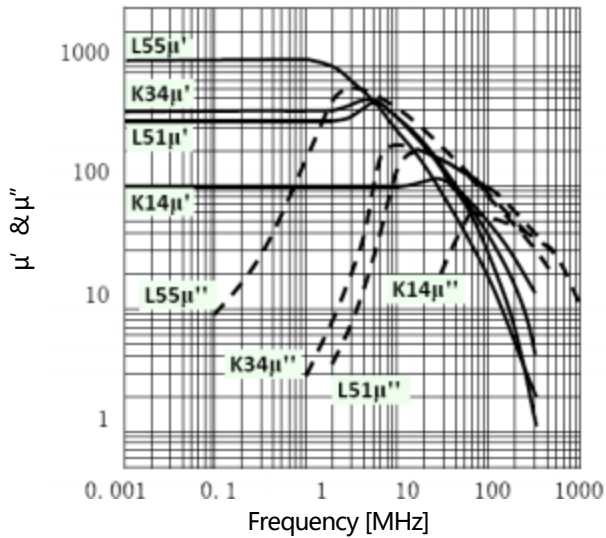

5. 超高频带域(~1000MHz)用铁氧体磁芯

A material for super wide frequency band (~1000MHz)

对于手提电话、PE-JIA等片式电感器最为合适。

Material name "DG10" is useful for chip inductors, handy phones and pager and so on.

材质名 Material	单位 Unit	μ —	ξ —	ρ [$\Omega \cdot \text{m}$]	d [g/cm 3]
DG10		1	14	10^{10}	5.0

● μ 频率特性

Frequency characteristic

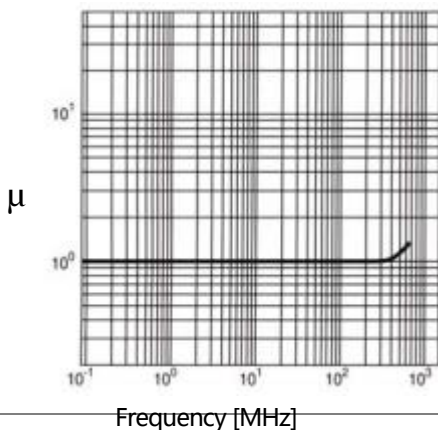

● |Z&|频率特性

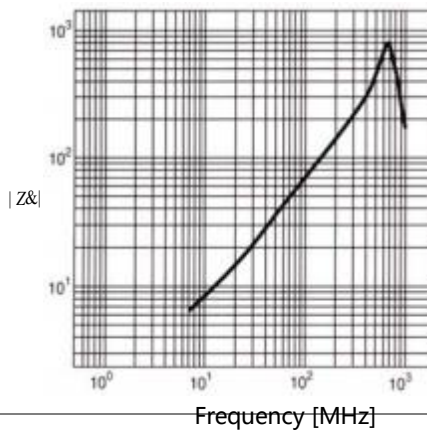

● Q值频率特性

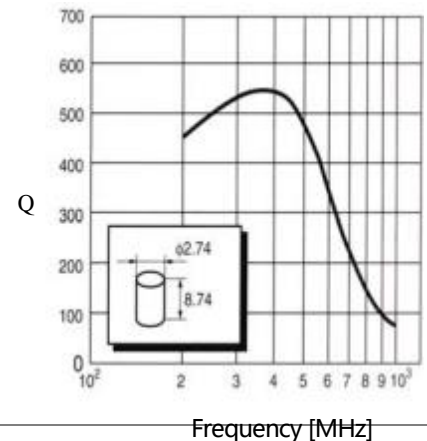

6. 变压器用材料 Materials for transformers

对于逆变变压器等小型化是较为有用的高电阻、低损耗材料。

Following materials are useful for the miniaturization of the inverter transformers etc.

特性项目 Parameter			DL68	DL62	DL61	DL47H	DL58	DL42H	DK34
初始磁导率 Initial permeability	μ_i	--	2000	1400	1300	750	750	600	400
相对损耗因数 Relative loss factor	$\tan\delta\mu_i$	10^6	30 (0.2MHz)	40 (0.2MHz)	20 (0.2MHz)	20 (0.4MHz)	18 (0.4MHz)	20 (0.4MHz)	18 (0.4MHz)
饱和磁通密度 Saturation magnetic flux density	B_{ms}	mT 20°C [4KA/m]	270	345	350	425	350	445	390
剩余磁通密度 Remanent flux density	B_r	mT 20°C [4KA/m]	200	185	130	290	140	180	185
矫顽力 Coercive force	H_c	A/m 20 4KA/m	13	10	6	2	12	2	1
功率损耗 Core loss	P_c	Kw/m 80°C f=50KHz Bm=150mT	345	250	405	230	505	570	490
居里温度 Curie temperature	T_c	°C	>110	>125	>135	>180	>170	>200	>160
电阻率 Electrical resistivity	ρ	$\Omega \cdot m$	10^6	10^6	10^6	10^6	10^6	10^6	10^6

● 功率损耗与温度变化曲线
Core Loss & Temperature

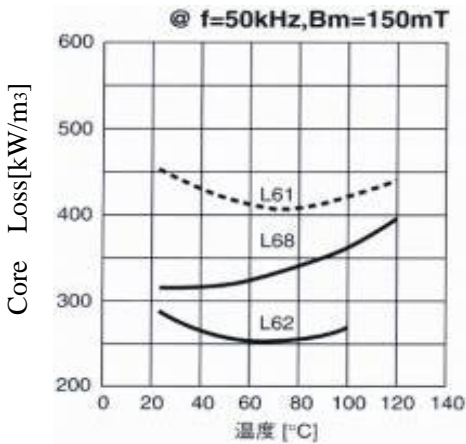

● 磁通密度与温度变化曲线
Saturation magnetic flux density & Temperature

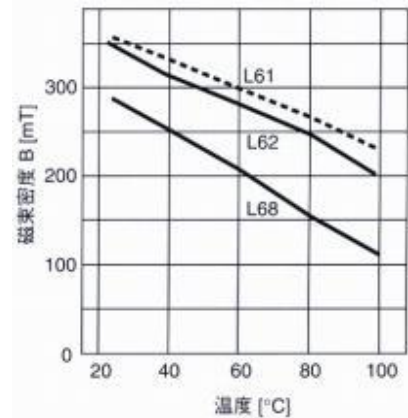

● B-H特性
B-H curve

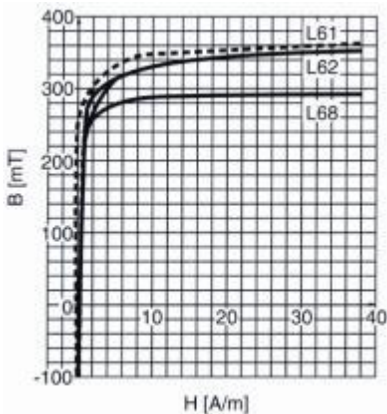

● μ' 及 μ'' 的频率特性
Frequency vs μ' , μ''

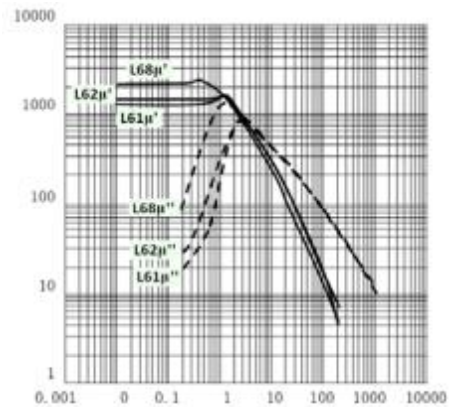

形状 Shapes

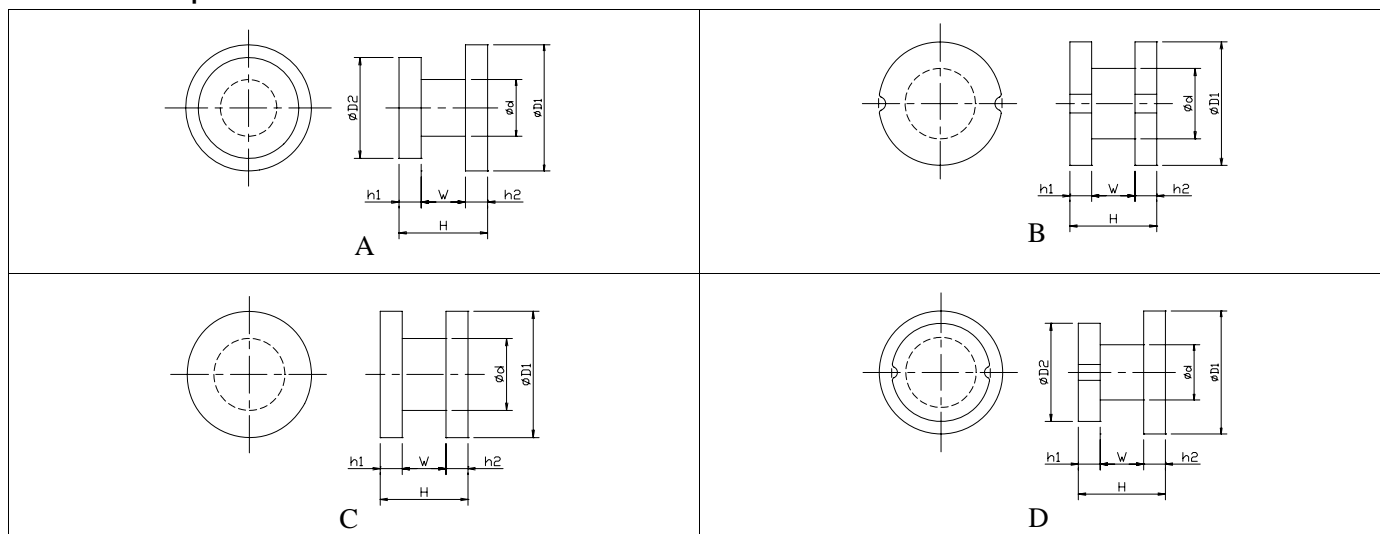

尺寸表 Dimensions(for example)

单位Unit: mm

品名	$\Phi D1$	$\Phi D2$	Φd	H	h1	h2	W	种类
B2813SF	2.8±0.1	2.1±0.1	1.20±0.1	1.30±0.1	0.30±0.1	0.30±0.1	0.70±0.1	D
B2808F	2.8±0.1	2.0±0.1	0.85±0.1	0.85±0.1	0.23±0.1	0.23±0.1	0.39±0.1	A
B2810F(FB)	2.8±0.1	2.0±0.1	0.85±0.1	1.05±0.1	0.275±0.07	0.275±0.07	0.50±0.1	A
(B28)13F(FB)	2.8±0.1	2.0±0.1	1.20±0.1	1.35±0.07	0.30±0.1	0.30±0.1	0.75±0.1	A
B2817F	2.8±0.1	2.0±0.1	1.0±0.1	1.75±0.1	0.32±0.07	0.32±0.07	1.11±0.07	A
B2412S	2.38±0.07	/	1.12±0.07	1.2±0.07	0.27±0.07	0.27±0.07	0.66±0.07	B
B3510F	3.5±0.07	2.6±0.07	1.2±0.07	1.0±0.07	0.28±0.07	0.28±0.07	0.44±0.07	A
B3513F	3.5±0.1	2.6±0.1	1.2±0.1	1.35±0.1	0.4±0.1	0.4±0.1	0.55±0.1	A
B3515F(FB)	3.5±0.1	2.6±0.1	1.2±0.1	1.5±0.1	0.4±0.1	0.4±0.1	0.70±0.1	A
B3517F	3.5±0.1	2.6±0.1	1.4±0.1	1.7±0.1	0.4±0.1	0.4±0.1	0.9±0.1	A
B3527F	3.5±0.1	2.6±0.1	1.6±0.1	2.7±0.1	0.45±0.1	0.45±0.1	1.8±0.1	A
B4310F	4.3±0.08	3.3±0.07	1.5±0.07	0.98±0.07	0.30±0.07	0.30±0.07	0.38±0.07	A
B4717F	4.7+0/-0.2	3.3±0.1	1.6±0.1	1.7±0.1	0.4±0.1	0.4±0.1	0.9±0.1	A
B4721F	4.7+0/-0.2	3.3±0.1	2.1±0.1	2.1±0.1	0.45±0.1	0.45±0.1	1.2±0.1	A
B4727F(FB)	4.7+0/-0.2	3.3±0.1	2.0±0.1	2.7±0.1	0.45±0.1	0.45±0.1	1.8±0.1	A
B3818SA(SB)	3.8±0.1	/	1.25±0.1	1.75±0.1	0.4±0.1	0.4±0.1	0.95±0.1	B
B3827SA(SB)	3.8±0.1	/	1.55±0.1	2.75±0.1	0.45±0.1	0.45±0.1	1.85±0.1	B
B3518	3.5±0.05	/	1.3±0.08	1.8±0.1	0.48±0.07	0.48±0.07	0.84±0.07	C
B5228F	5.2±0.1	3.8±0.07	2.0±0.1	2.75±0.1	0.45±0.1	0.45±0.1	1.85±0.1	A
B5617F(FB)	5.6±0.1	4.1±0.1	1.8±0.1	1.7±0.1	0.45±0.1	0.45±0.1	0.8±0.1	A
B5627F	5.6±0.1	4.1±0.1	2.0±0.1	2.7±0.1	0.45±0.1	0.45±0.1	1.8±0.1	A

形状 Shapes

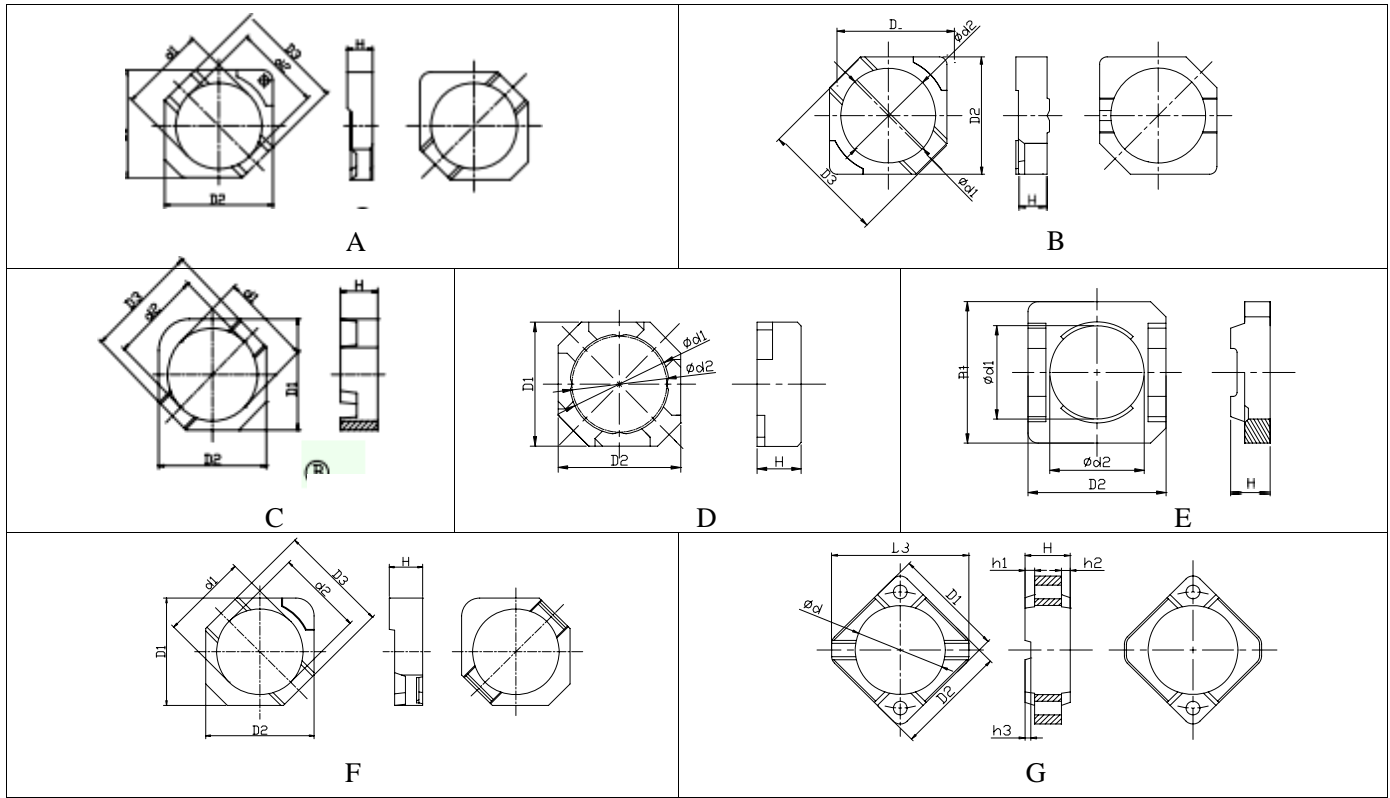

尺寸表 Dimensions(for example)

单位Unit: mm

品名	D1	D2	D3	Φd1	Φd2	H	种类
FRQ3/2.4/1.2	3.0±0.1	3.0±0.1	3.04±0.1	2.40±0.1	2.40±0.1	1.20±0.1	F
FRQ3/2.5/0.75	3.0±0.15	3.0±0.15	3.04±0.1	2.4+0.15/-0.05	2.4+0.15/-0.05	0.75±0.1	A
FRQ3/2.5/0.9	3.0±0.1	3.0±0.1	3.04±0.1	2.40±0.1	2.40±0.1	0.92±0.1	A
FRQ3/2.5/1.2(A)	3.0±0.1	3.0±0.1	3.04±0.1	2.40±0.1	2.40±0.1	1.15±0.1	A
FRQ3/2.5/1.6	3.0±0.1	3.0±0.1	3.04±0.1	2.50±0.1	2.50±0.1	1.60±0.1	A
FRQ3.2/2.6/1.2	3.2+0.04/-0.07	3.2+0.04/-0.07	/	2.58±0.04	2.48±0.04	1.15±0.05	D
FRQ3.8/3.1/0.9(A)	3.8±0.12	3.8±0.12	3.95±0.1	3.1+0.12/-0.07	3.1+0.12/-0.07	0.92±0.07	A
FRQ3.8/3.1/1.2	3.8±0.1	3.8±0.1	3.97±0.1	3.1+0.15/-0.1	3.1+0.1/-0.15	1.2±0.1	A
FRQ3.8/3.1/1.4	3.8±0.1	3.8±0.1	3.97+0.03/-0.1	3.1±0.1	3.1±0.1	1.35±0.1	A
FRQ3.8/3.1/1.6	3.8±0.1	3.8±0.1	3.97±0.1	3.1±0.07	3.1±0.07	1.55±0.07	A
FRQ3.8/3.1/2.6	3.8±0.1	3.8±0.1	3.97±0.1	3.1+0.15/-0.05	3.1+0.07/-0.15	2.55±0.1	A
FRQ4.6/3.8/0.9	4.6±0.07	4.6±0.07	4.8±0.07	3.8±0.07	3.8±0.07	0.9±0.1	A
FRQ4.7/3.9/1.5	4.7±0.1	4.7±0.1	4.9±0.1	3.9+0.15/-0	3.8+0.15/-0	1.4±0.1	B
FRQ4.7/3.9/1.9	4.75±0.1	4.75±0.1	4.9±0.1	3.9+0.1/-0.05	3.9+0.1/-0.05	1.8±0.1	B
FRQ4.7/3.9/2.5	4.7±0.1	4.7±0.1	4.9±0.1	3.9+0.15/-0.1	3.9+0.15/-0.1	2.4±0.1	B
FRQ4.9/4.1/1.7	4.9±0.1	4.9±0.1	5.16±0.1	4.1±0.07	4.1±0.09	1.7±0.1	C
FRQ4.9/4.1/2.7	4.9±0.1	4.9±0.1	5.16±0.1	4.1±0.07	4.1±0.07	2.7±0.1	C
FRQ5.6/3.7/1.6	5.6±0.15	5.4±0.15	/	3.7+0.15/-0.08	3.7+0.2/-0.08	1.55±0.12	E
FRQ5.7/4.6/2.3	5.7±0.3	5.7±0.3	7.0±0.3	4.6±0.1	/	2.3±0.07	G
FRQ5.8/4.7/1.5	5.8+0/-0.2	5.8+0/-0.2	6.0±0.1	4.7+0.15/-0	4.7+0.15/-0	1.5+0.05/-0.15	B
FRQ5.8/4.7/2.5	5.85+0/-0.2	5.85+0/-0.2	6.0	4.7+0.15/-0	4.7+0.15/-0	2.5+0.05/-0.15	B

形状 Shapes

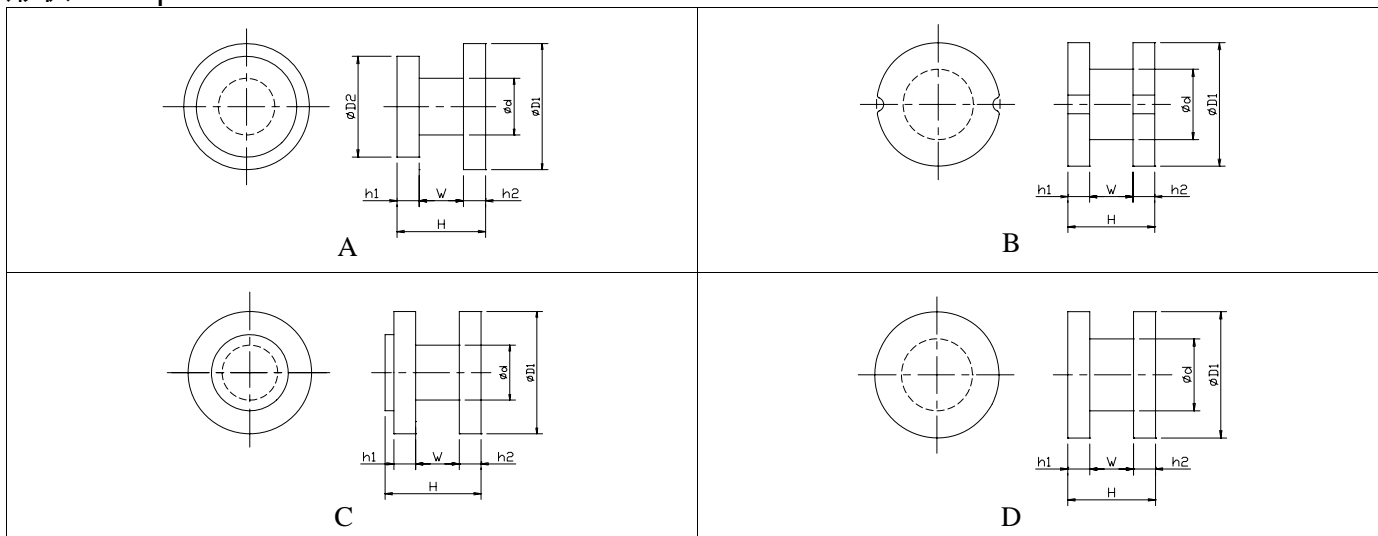

尺寸表 Dimensions(for example)

单位Unit: mm

品名	$\Phi D1$	$\Phi D2$	Φd	H	h1	h2	W	种类
B5727F	5.7+0/-0.2	4.1±0.1	2.0±0.1	2.7±0.07	0.45±0.1	0.45±0.1	1.8±0.07	A
B5732F	5.7+0/-0.2	4.1±0.1	2.0±0.1	2.7±0.07	0.45±0.1	0.45±0.1	2.3±0.07	A
B4913S	4.9±0.07	/	1.9±0.07	1.3±0.07	(0.4)	(0.4)	0.5±0.07	B
B4918S	4.9±0.07	/	2.0±0.07	1.3±0.07	(0.4)	(0.4)	1.0±0.07	B
B4421(A)	4.35±0.1		2.0±0.1	2.1±0.07	(0.6)	(0.6)	0.9±0.05	D
B4426(A)	4.35±0.1		2.0±0.1	2.6±0.06	(0.6)	(0.6)	1.4±0.08	D
B4117	4.1±0.1	/	2.0±0.1	1.7±0.07	0.45±0.07	0.45±0.07	0.8±0.1	D
B4120(A)	4.1±0.1	/	1.6±0.1	2.0±0.1	0.55±0.07	0.55±0.07	0.9±0.1	D
B4130	4.1±0.1	/	2.0±0.1	3.0±0.1	0.5±0.07	0.5±0.07	2.0±0.1	D
B4824	4.8±0.07	/	2.0±0.07	2.35±0.07	0.55±0.07	0.55±0.07	1.0±0.07	C
B4827	4.8±0.07	/	2.0±0.07	2.65±0.07	0.55±0.07	0.55±0.07	1.3±0.07	C
B6627FA(FB)	6.6±0.1	4.8±0.1	2.3±0.1	2.7±0.1	0.5±0.1	0.5±0.1	1.7±0.1	A
B6637F(FC)	6.6±0.1	4.8±0.1	2.6±0.1	3.7±0.1	0.5±0.1	0.5±0.1	2.7±0.1	A
B4517SA(SB)	4.5±0.1	/	2.0±0.1	1.7±0.07	0.5±0.07	0.5±0.07	(0.7±0.07)	B
B4527SA(SB)	4.5±0.07	/	2.0±0.07	2.7±0.07	0.55±0.07	0.55±0.07	1.6±0.07	B

闭合磁路类功率电感用磁芯 SMD TUPE CORES

形状 Shapes

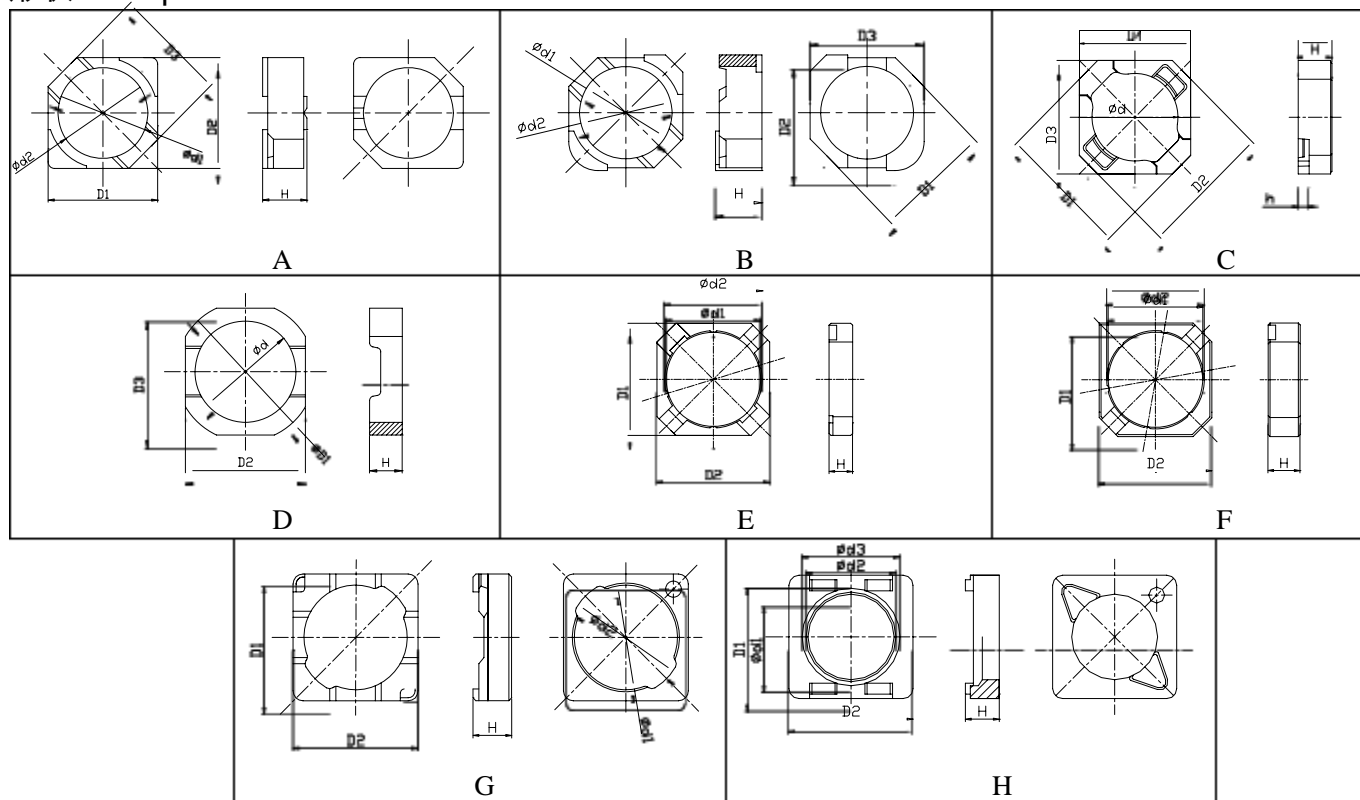

尺寸表 Dimensions(for example)

单位Unit: mm

品名	D1	D2	D3	Φd1	Φd2	Φd3	H	种类
FRQ6/4.7/2.4(A)	6.0±0.1	5.9±0.1	6.1±0.1	4.8±0.1	4.73±0.08	/	2.4±0.1	B
FRQ6/4.7/2.9A	6.0±0.1	5.9±0.1	6.0±0.1	4.7+0.15/-0	4.7+0.15/-0	/	2.9±0.1	B
FRQ6/5.2/1.3	6.0±0.1	6.0±0.1	/	(5.05)	5.2±0.08	/	1.25±0.1	E
FRQ6/5.2/1.7	6.0±0.1	6.0±0.1	/	(5.05)	5.2±0.08	/	1.70±0.1	F
FRQ6.1/4.7/1.9	7.2±0.2	7.2±0.2	6.1±0.15	4.7±0.1	/	/	1.85±0.07	C
FRQ6.1/4.7/2.4	7.2±0.2	7.2±0.2	6.1±0.15	4.7±0.1	/	/	2.35±0.07	C
FRQ6.2/4.3/1.4	6.2±0.1	6.2±0.1	/	4.30±0.07	4.5±0.1	4.9±0.1	1.4±0.1	H
FRQ6.2/4.3/1.7	6.2±0.1	6.2±0.1	/	4.30±0.07	4.5±0.1	4.9±0.1	1.7±0.1	H
FRQ6.2/4.3/2.7	6.2±0.1	6.2±0.1	/	4.30±0.07	4.5±0.1	4.9±0.1	2.7±0.1	H
FRQ6.3/5.2/2	6.3±0.07	6.3±0.07	/	5.2±0.06	5.8±0.07	/	1.95±0.07	G
FRQ6.3/5.2/2.3	6.3±0.07	6.3±0.07	/	5.2±0.06	5.8±0.07	/	2.25±0.07	G
FRQ6.8/5.5/2.5	6.8+0/-0.2	6.8+0/-0.2	7.0±0.1	5.5+0.15/-0	5.5+0.15/-0	/	2.5±0.1	A
FRQ6.8/5.5/3.5	6.85+0/-0.2	6.85+0/-0.2	7.0±0.1	5.5+0.15/-0	5.5+0.15/-0	/	3.5±0.1	A
FRD6.6/4.8/1.6	6.6±0.1	5.7±0.1	6.0±0.1	4.8±0.1	/	/	1.55±0.07	D
FRD6.6/4.8/2.6	6.6±0.1	5.7±0.1	6.0±0.1	4.8±0.1	/	/	2.55±0.07	D

形状 Shapes

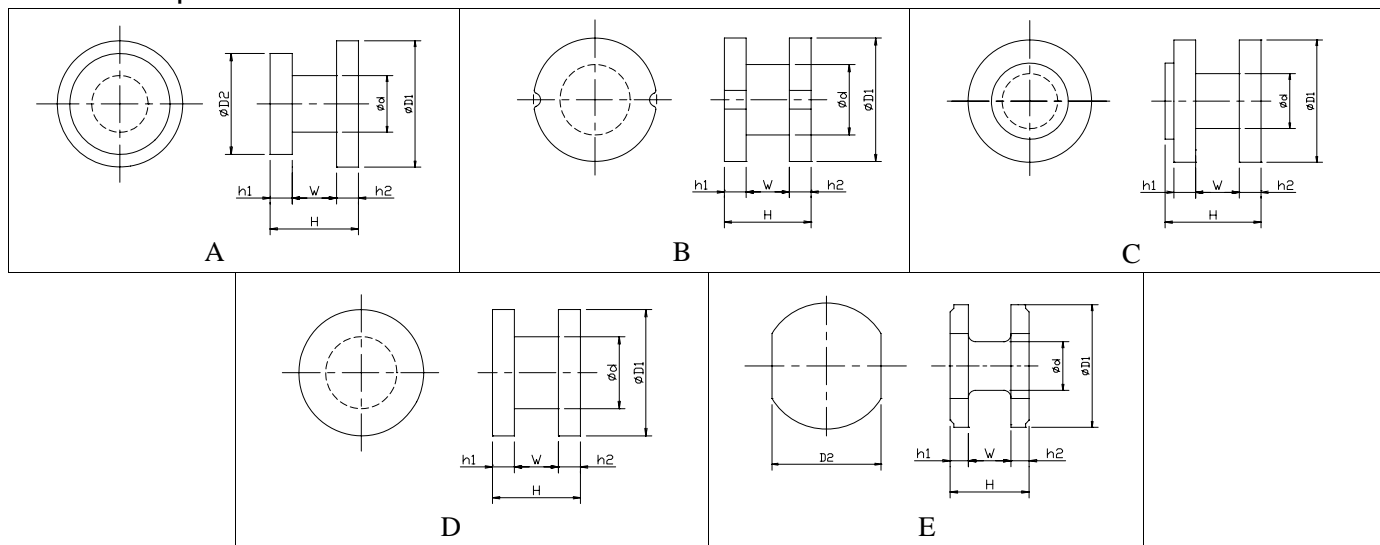

尺寸表 Dimensions(for example)

单位Unit: mm

品名	ΦD1	D2	Φd	H	h1	h2	W	种类
B4025	4.0±0.1	/	1.8±0.1	2.5±0.1	0.55±0.07	0.55±0.07	1.4±0.1	D
B4043	4.0±0.1	/	2.1±0.1	4.3±0.1	0.6±0.07	0.6±0.07	3.1±0.1	D
B4525	4.5±0.1	4.0±0.1	2.1±0.1	2.5±0.1	0.55±0.1	0.55±0.1	1.4±0.1	E
B4542	4.5±0.1	4.0±0.1	2.4±0.1	4.2±0.1	0.6±0.1	0.6±0.1	3.0±0.1	E
B5341S	5.3±0.1	/	2.5±0.05	4.1±0.07	0.6±0.05	0.6±0.05	2.9±0.07	B
B7026	7.0±0.1	/	2.6±0.1	2.6±0.1	0.65±0.1	0.65±0.1	1.05±0.1	C
B5337	5.3±0.15	/	2.8±0.1	3.7±0.15	0.6±0.15	0.6±0.15	2.5±0.15	D
B5328	5.3±0.15	/	2.5±0.1	2.8±0.15	0.6±0.15	0.6±0.15	1.6±0.15	D
B8027FA(FB)	8.0±0.1	5.8±0.1	3.0±0.1	2.7±0.1	0.6±0.1	0.6±0.1	1.5±0.07	A
B8037F	8.0±0.1	5.8±0.1	4.0±0.1	3.7±0.1	0.8±0.1	0.8±0.1	2.1±0.1	A
B8042F	8.0±0.1	5.8±0.1	4.0±0.1	2.7±0.1	0.8±0.1	0.8±0.1	4.2±0.1	A
B8057F	8.0±0.1	5.8±0.1	4.0±0.1	5.7±0.1	0.85±0.1	0.85±0.1	4.0±0.1	A
B6360S	6.3±0.1	/	3.7±0.1	6.0±0.12	(0.8)	(0.8)	4.4±0.1	B
B5920	5.9±0.08	/	2.3±0.1	1.95±0.06	(0.55)	(0.55)	0.85±0.07	D
B5936	5.9±0.07	/	2.3±0.07	3.55±0.07	0.55±0.07	0.55±0.07	(2.45)	D
B6844	6.8±0.1	/	3.2±0.1	4.4±0.12	0.7±0.1	0.7±0.1	3.0±0.1	D
B7233	7.2±0.15	/	3.4±0.1	3.3±0.1	0.95±0.1	0.95±0.1	1.4±0.1	C

形状 Shapes

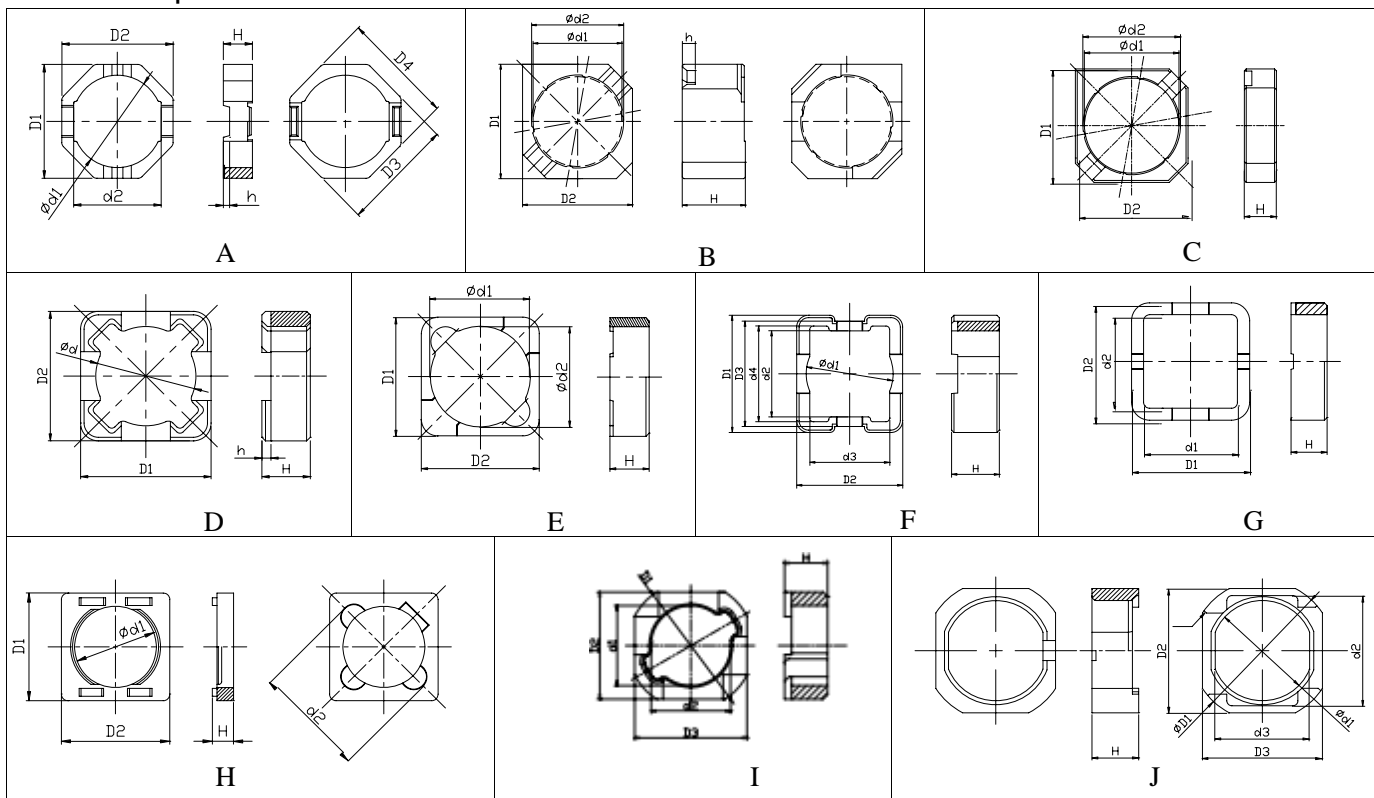

尺寸表 Dimensions(for example)

单位Unit: mm

品名	D1	D2	D3	d1	d2	d3	H	种类
FRD7/4.4/2.4	7.0±0.1	5.9±0.1	6.2±0.1	4.4+0.15/-0	4.4+0.15/-0	/	2.4±0.1	I
FRD7/4.4/4.1	7.0±0.1	5.9±0.1	6.2±0.1	4.4+0.15/-0	4.4+0.15/-0	/	4.1±0.1	I
FRD7/5/2.3	7.0±0.15	6.2±0.1	5.9±0.1	5.0+0.1/-0	5.5±0.1	4.65±0.1	2.3±0.12	J
FRD7/5/4	7.0±0.15	6.2±0.1	5.9±0.1	5.0+0.1/-0	5.5±0.1	4.65±0.1	4.0±0.15	J
FRQ7/5.7/3.9	7.0±0.07	6.8±0.07	/	5.5±0.1	5.7±0.05	/	3.9±0.07	B
FRQ7.2/6.1/2.4	7.2±0.12	7.2±0.12	/	6.1±0.1	6.1±0.1	/	2.4±0.1	E
FRQ7.3/5.6/3.5	7.3±0.15	7.3±0.15	/	5.6+0.15/-0	5.6+0.15/-0	/	3.6±0.15	D
FRQ7.3/5.7/2.7	7.3±0.15	7.3±0.15	/	5.6+0.15/-0	5.6+0.15/-0	/	2.7±0.15	D
FRQ8/6.5/2.1	8.0±0.15	8.0±0.15	8.0±0.15	6.5±0.1	6.5±0.1	/	2.1±0.1	A
FRQ8/6.5/3.1	8.0±0.15	8.0±0.15	8.0±0.15	6.5±0.1	6.5±0.1	/	3.1±0.1	A
FRQ8/6.5/3.4	8.0±0.15	8.0±0.15	8.0±0.15	6.5±0.1	6.5±0.1	/	3.4±0.1	A
FRQ8/6.5/4.8	8.0±0.15	8.0±0.15	8.0±0.15	6.5±0.1	6.5±0.1	/	4.8±0.1	A
FRQ8/6.7/5.8	8.0±0.15	8.0±0.15	/	(6.5)	6.7±0.15	/	5.8±0.15	C
FRQ8.2/6.2/1.6	8.2±0.1	8.2±0.1/-0.2	/	6.2±0.1	8.4±0.15	/	1.6±0.1	H
FRQ8.2/6.2/3.2	8.2±0.1	8.2±0.1	/	6.2±0.1	8.4±0.15	/	3.2±0.1	H
FRQ9.8/7.3/4	9.8±0.15	8.9±0.15	8.8±0.15	7.3+0.15/-0	7.2±0.15	6.7±0.15	4.0±0.1	F
FRQ9.8/7.8/3	9.8±0.15	9.8±0.15	/	7.8±0.15	7.8±0.15	/	3.0±0.15	G

闭合磁路类功率电感用磁芯 SMD TUPE CORES

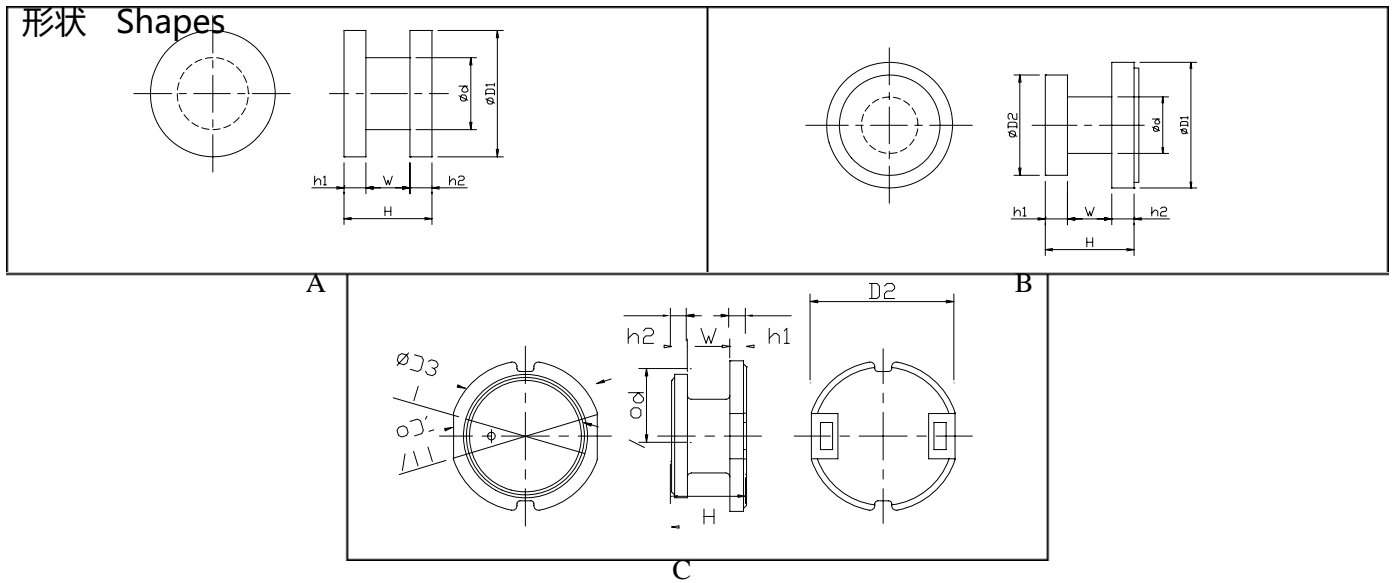

尺寸表 Dimensions (for example)

单位Unit: mm

品名	ΦD1	D2	ΦD3	Φd	H	h1	h2	W	种类
B9827F	9.8+0/-0.25	7.6 +0/-0.2	/	4.0±0.1	2.65±0.1	0.75±0.1	0.85±0.1	0.95±0.1	B
B9837FB	9.8+0/-0.25	7.6 +0/-0.2	/	4.8±0.1	3.65±0.1	0.85±0.1	0.85±0.1	1.95±0.1	B
B9847F	9.8+0/-0.25	7.6 +0/-0.2	/	4.8±0.1	4.65±0.1	0.85±0.1	0.85±0.1	2.95±0.1	B
B9441F	9.4±0.15	6.0±0.2	/	5.0±0.1	4.1±0.1	1.1±0.1	1.0±0.1	2.0±0.1	B
B9442(FA、FB)	9.4±0.15	8.0±0.08	/	5.2±0.1	(4.2±0.1)	1.05±0.1	1.05±0.1	2.0±0.1	B
10050SF	10.0±0.15	9.5±0.1	8.2±0.12	4.9±0.075	4.95+0/-0.3	1.1+0/-0.15	(1.0)	2.8±0.1	C
B7925(A)	7.9±0.1	/	/	3.9±0.1	2.5±0.07	(0.7)	(0.7)	1.1±0.05	A
B7943A(B)	7.9±0.1	/	/	3.9±0.1	4.3±0.1	(0.8)	(0.8)	2.7±0.1	A
B11442FA(B、C)	11.4±0.15	9.95±0.1	/	5.6±0.15	4.2±0.1	1.1±0.12	1.0±0.12	2.0±0.12	B
B10039	10.0±0.1	/	/	5.0±0.1	3.9±0.1	1.0±0.1	1.0±0.1	1.9±0.1	A
B10053	10.0±0.1	/	/	5.2±0.1	5.3+0/-0.2	1.15±0.1	1.15±0.1	2.9±0.1	A
B11477FA(B)	11.4±0.1	9.95±0.1	/	6.5±0.1	(7.65)	1.5±0.1	1.5±0.1	4.55±0.1	B
B10071	10.0±0.1	/	/	6.3±0.1	7.1±0.1	1.1±0.1	1.1±0.1	4.9±0.1	A
B10070	10.0±0.1	/	/	6.2±0.1	7.0±0.1	1.0±0.1	1.0±0.1	5.0±0.1	A

闭合磁路类功率电感用磁芯 SMD TUPE CORES

形状 Shapes

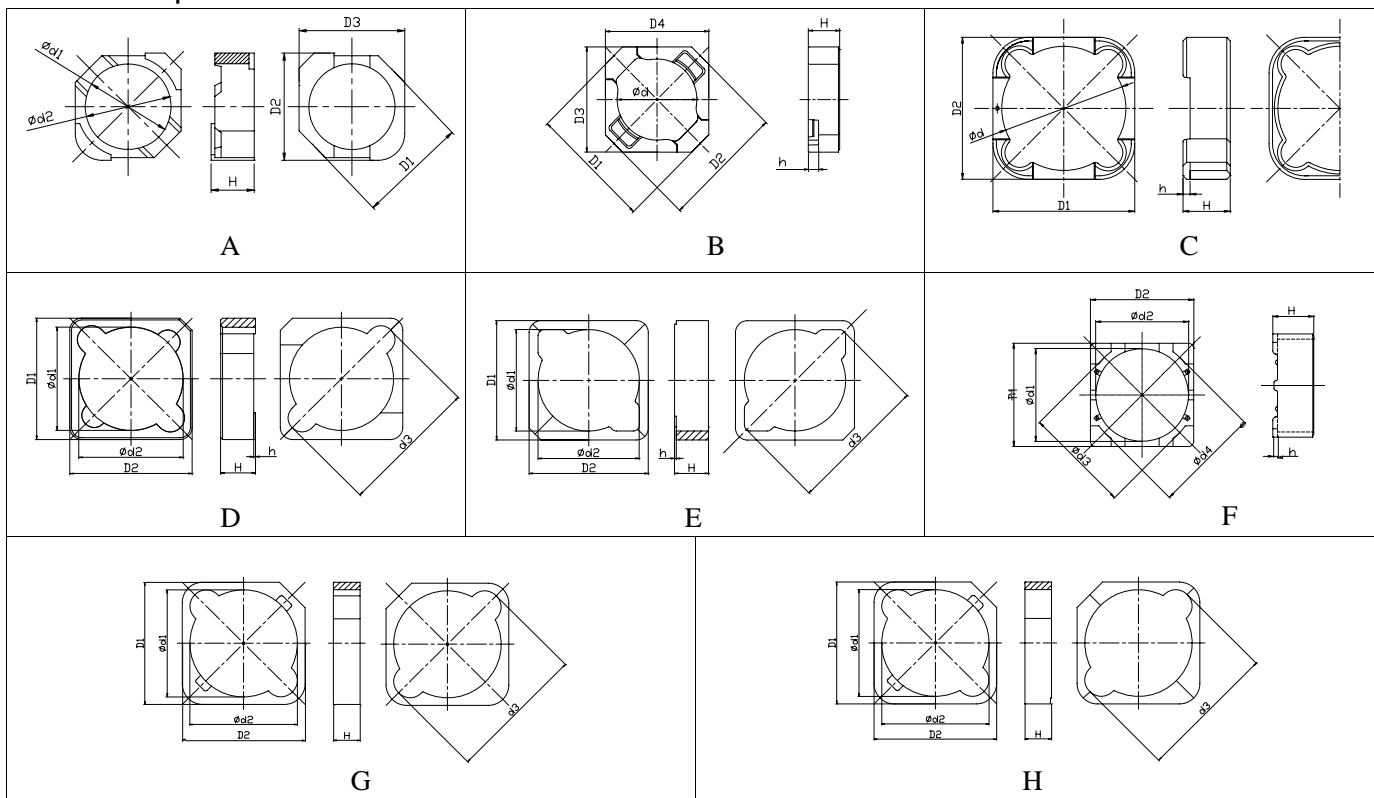

尺寸表 Dimensions(for example)

单位Unit: mm

品名	D1	D2	D3	d1	d2	d3	H	种类
FRQ10/8.2/2.3	10.0±0.3	10.0±0.3	10.5±0.1	8.2+0.15/-0.05	8.2+0.05/-0.15	/	2.25±0.1	A
FRQ10/8.2/3.4	10.0±0.3	10.0±0.3	10.5±0.1	8.2+0.15/-0.05	8.2+0.05/-0.15	/	3.35±0.1	A
FRQ10/8.2/4.3	10.0±0.3	10.0±0.3	10.5±0.1	8.2+0.15/-0.05	8.2+0.05/-0.15	/	4.25±0.1	A
FRQ10/8.5/2.85	10.0±0.18	10.0±0.18	/	8.5±0.1	8.5±0.1	11.4±0.2	2.85±0.1	D
FRQ10/8.5/2.9	10.0±0.2	10.0±0.2	/	8.5±0.1	8.5±0.1	11.6±0.2	2.85±0.1	E
FRQ10/8.9/3.7	10.0±0.15	10.0±0.15	/	8.85+0.3/-0	8.85+0.3/-0	10.15+0.3/-0	3.65+0/-0.3	F
FRQ10.1/8.4/2.0	10.1±0.2	10.1±0.2	12.01±0.25	8.4±0.15	8.8±0.2	/	2.0±0.05	B
FRQ10.1/8.4/3.8	10.1±0.2	10.1±0.2	12.01±0.25	8.4±0.15	8.8±0.2	/	3.75±0.1	B
FRQ12/10.5/2.7	12.0±0.18	12.0±0.18	/	10.5+0.5/-0.15	10.5+0.5/-0.15	13.5±0.2	2.7±0.1	G
FRQ12/10.5/3.7	12.0±0.2	12.0±0.2	/	10.4+0.3/-0	10.4+0.3/-0	/	3.65±0.1	C
FRQ12/10.5/5.1	12+0.25/-0.2	12+0.25/-0.2	/	10.4+0.3/-0	10.4+0.3/-0	/	5.1±0.15	C
FRQ12/10.5/6.1	12.0±0.18	12.0±0.18	/	10.5+0.5/-0.15	10.5+0.5/-0.15	13.5±0.2	6.1±0.1	H
FRQ12/10.5/6.6	12+0.25/-0.2	12+0.25/-0.2	/	10.4+0.3/-0	10.5±0.2	/	6.6±0.2	C
FRQ12.2/10.7/6.6	12.1±0.2	12.1±0.2	/	10.7+0.2/-0.1	10.7+0.2/-0.1	/	6.6±0.2	C

闭合磁路类功率电感用磁芯 SMD TUPE CORES

形状 Shapes

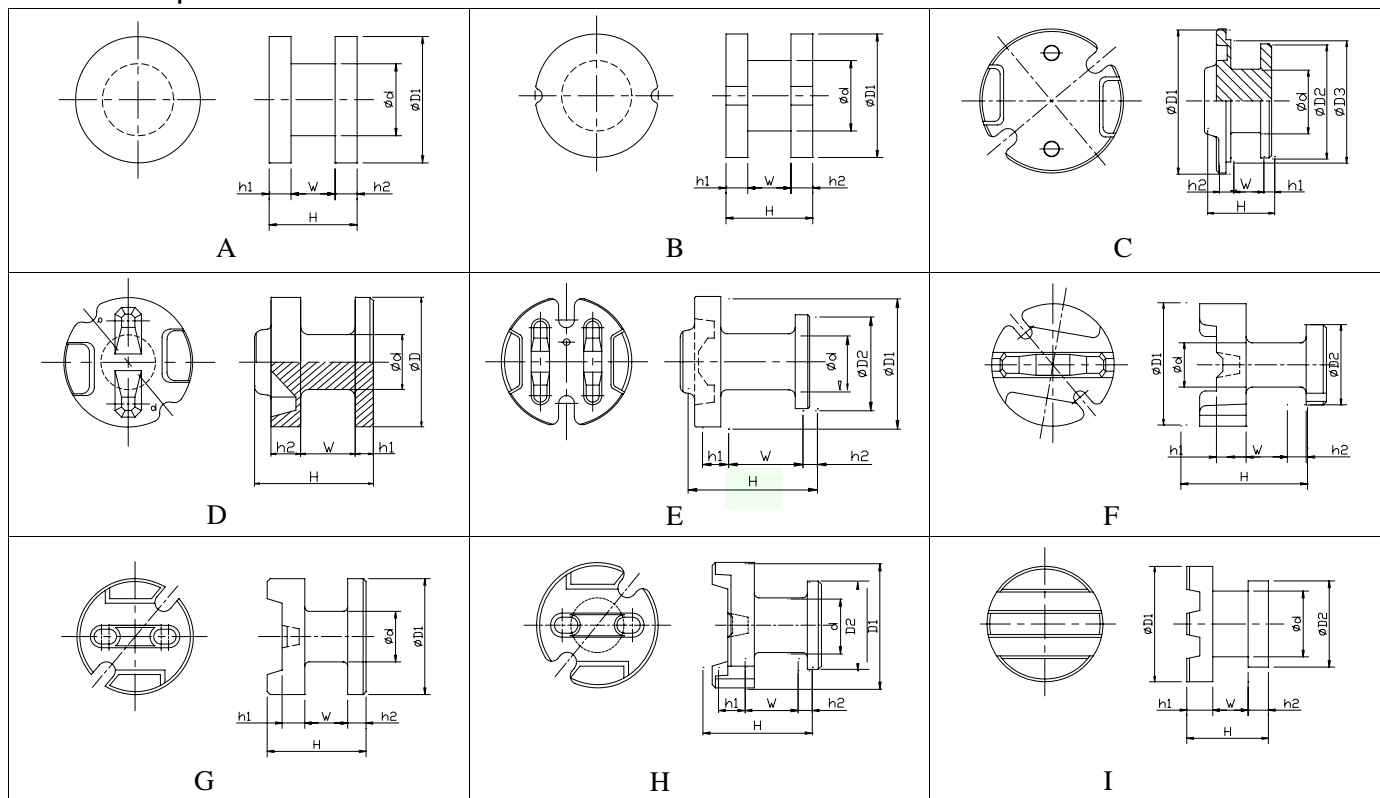

尺寸表 Dimensions(for example)

单位Unit: mm

品名	ΦD1	ΦD2	ΦD3	Φd	H	h1	h2	W	种类
B5860SF	5.8±0.1	3.8±0.07	/	2.1±0.1	6.0±0.2	1.4±0.12	0.8±0.12	3.0±0.15	F
B7835F	7.8±0.2	5.5±0.2	/	3.0±0.1	3.5±0.2	1.55±0.15	0.65±0.15	1.3±0.15	I
B7847F	7.8±0.2	5.5±0.2	/	3.0±0.1	4.7±0.2	1.6±0.15	0.8±0.15	2.3±0.15	I
B7870SF	7.8±0.2	5.5±0.2	/	3.4±0.15	7.0±0.2	1.7±0.2	0.9±0.16	3.4±0.15	H
B7060A	7.0±0.1	/	/	4.0±0.1	6.0±0.15	1.0±0.1	1.0±0.1	(4.0)	A
B10079SF	10.0±0.12	7.2±0.12	/	3.9±0.12	7.9±0.2	2.0±0.12	1.1±0.1	3.7±0.15	E
B10099SF	10.0±0.12	7.2±0.12	/	4.3±0.12	9.9±0.2	2.0±0.12	1.1±0.1	5.7±0.15	E
B7637	7.6±0.1	/	/	3.6±0.1	3.7±0.1	0.7±0.1	0.7±0.1	2.3±0.1	A
B7624S	7.55±0.15	/	/	2.5±0.15	2.4±0.15	(0.75)	(0.75)	0.9±0.15	B
B7635S	7.55±0.15	/	/	3.6±0.15	3.5±0.15	(0.8)	(0.8)	1.9±0.15	B
B7530	7.5+0/-0.2	/	/	2.5±0.1	3.0±0.1	0.8±0.1	0.8±0.1	1.4±0.1	A
B9643	9.6±0.15	/	/	4.5±0.15	4.3±0.15	0.85±0.15	0.85±0.15	2.6±0.15	A
B9655	9.6±0.15	/	/	4.0±0.15	5.5±0.15	1.5±0.15	1.5±0.15	2.5±0.15	A
B9665	9.6±0.15	/	/	5.55±0.15	6.5±0.15	1.05±0.15	1.05±0.15	4.4±0.15	A
B10065	10.0±0.2	/	/	5.5±0.1	6.5±0.15	1.0±0.15	1.0±0.15	4.5±0.15	A
B12056SF	12.0±0.2	9.5±0.2	10.2±0.15	5.3±0.15	5.6±0.2	0.9±0.2	1.2±0.2	(2.5)	C
B4517	4.5±0.05	/	/	1.4±0.1	1.65±0.1	0.48±0.1	0.48±0.1	0.69±0.1	A
B4521D	4.5±0.07	/	/	1.4±0.1	2.1±0.1	0.5±0.1	0.5±0.1	1.1±0.1	A
B4530D	4.5±0.07	/	/	1.5±0.1	3.0±0.1	0.65±0.1	0.65±0.1	1.7±0.1	A
B5321	5.3±0.1	/	/	1.8±0.1	2.1±0.1	0.5±0.1	0.5±0.1	1.1±0.1	A
B5331	5.3±0.1	/	/	2.0±0.1	3.1±0.1	0.6±0.1	0.6±0.1	1.9±0.1	A
B7855C(E)	7.8+0/-0.3	/	/	3.0±0.2	5.5+0.15/-0.5	1.15±0.15	1.15±0.15	3.2±0.15	A
B7870S(SB)	7.8±0.2	/	/	3.4±0.15	7.0±0.2	1.7±0.1	0.9±0.1	3.4±0.15	G
B7872SD	7.8±0.2	/	/	3.3±0.15	7.2±0.2	1.1±0.15	1.8±0.15	3.3±0.15	D

形状 Shapes

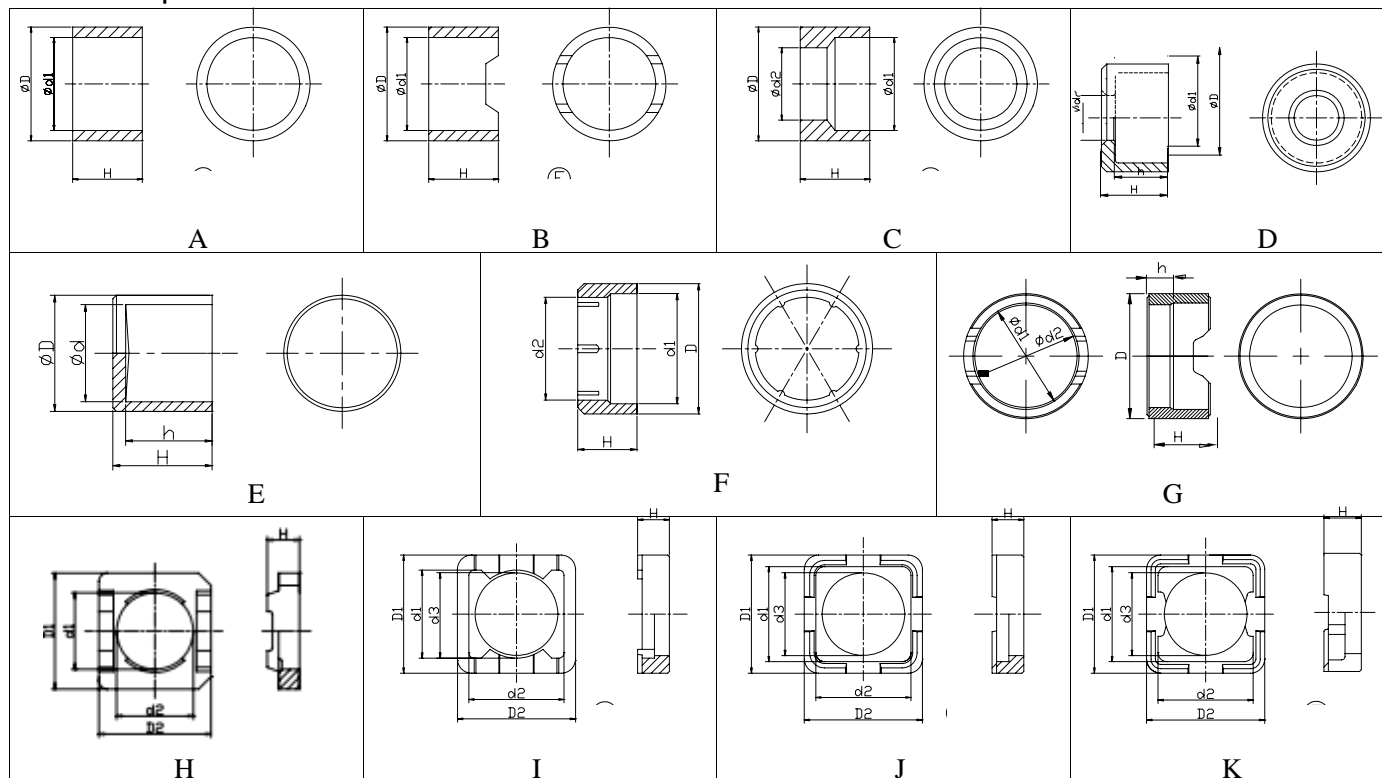

尺寸表 Dimensions(for example)

单位Unit: mm

品名	ΦD1	ΦD2	Φd1	Φd2	Φd3	H	h	种类
FR5.8/4.6/3.5	5.8±0.15	/	4.6±0.1	/	/	3.5±0.12	/	A
FR7.8/6.4/1.8	7.8±0.2	/	6.4+0.2/-0.1	/	/	1.8±0.15	/	B
FR7.8/6.4/3	7.8±0.15	/	6.4+0.15/-0.1	/	/	3.0±0.12	/	B
FR7.8/6.4/4.2	7.8±0.2	/	6.4+0.2/-0.1	/	/	4.2±0.15	/	B
FR10/8/5.3	10.0±0.15	/	8.0±0.1	/	/	5.3±0.15	/	B
FR10/8.2/4.5	10.0±0.15	/	8.2±0.15	/	/	4.5±0.2	/	A
FR10/8.2/6.5	10.0±0.15	/	8.2±0.15	/	/	6.5±0.2	/	A
FR10/8.5/3.6	10.0±0.15	/	8.5±0.15	/	/	3.6±0.1	1.3±0.15	G
FR10.1/7.7/1.8	10.1±0.15	/	8.7±0.15	7.65+0.15/-0.05	/	1.8±0.12	/	C
FR10.1/7.7/2.9	10.1±0.15	/	8.7±0.15	7.65+0.15/-0.05	/	2.9±0.12	/	C
FR10.1/7.7/3.2	10.1±0.15	/	8.7±0.15	7.7±0.15	/	3.2±0.12	/	C
FR12.2/10.2/4.1	12.2±0.2	/	10.2±0.15	(10.38)	/	4.1±0.15	(1.95)	G
FR12.2/10.2/5.3	12.2±0.2	/	10.2±0.2	10.6±0.2	/	5.3±0.15	(1.95)	G
FR12.2/10.2/6.2	12.2±0.2	/	10.2±0.2	10.6±0.2	/	6.2±0.15	2.6±0.15	G
FR12.4/10.5/5.6	12.4±0.2	/	10.5+0.3/-0	9.8+0.2/-0.1	/	5.6±0.15	/	F
FR12.4/10.6/2.7	12.4±0.2	/	10.6±0.2	/	/	2.7±0.2	/	A
LQ6713A	6.7±0.15	6.7±0.15	5.0±0.15	5.4±0.15	4.7±0.15	1.3±0.1	/	I
LQ6718E	6.7±0.15	6.7±0.15	5.4±0.15	5.4±0.15	4.7±0.1	1.8±0.1	/	K
LQ6727E	6.7±0.15	6.7±0.15	5.4±0.15	5.4±0.15	4.7±0.1	2.7±0.1	/	K
LQ7718	7.7±0.15	7.7±0.15	6.5±0.15	6.1±0.15	5.6±0.1	1.8±0.1	/	J
LQ7728	7.7±0.15	7.7±0.15	6.5±0.15	6.1±0.15	5.6±0.1	2.8±0.1	/	J
LP1006	10.15+0/-0.3	/	8.5±0.2/-0	4.2±0.2	/	6.3±0/-0.4	5.0±0.2	D
P10086	10.15+0.2/-0.1	/	8.5+0.2/-0.1	/	/	8.6±0.2	7.5+0.1/-0.2	E
P10286	10.15+0.2/-0.1	/	8.5+0.2/-0.1	/	/	8.6±0.2	7.5+0.1/-0.2	E



关于工型磁芯的产品命名 Naming of drum core models

【例】 Example

DL52 B 140 145 □ — □

辅助记录(多缘) Sub-symbol(★)

辅助记号(高度、外径尺寸相同, 区别于其他尺寸不同的型号) Sub-symbol(☆)

H 尺寸 Height

D 尺寸 Diameter

形状记号 shape symbol

材质名 Material name

工型磁芯 DRUM CORES

形状 Shapes (Ø1 系列)

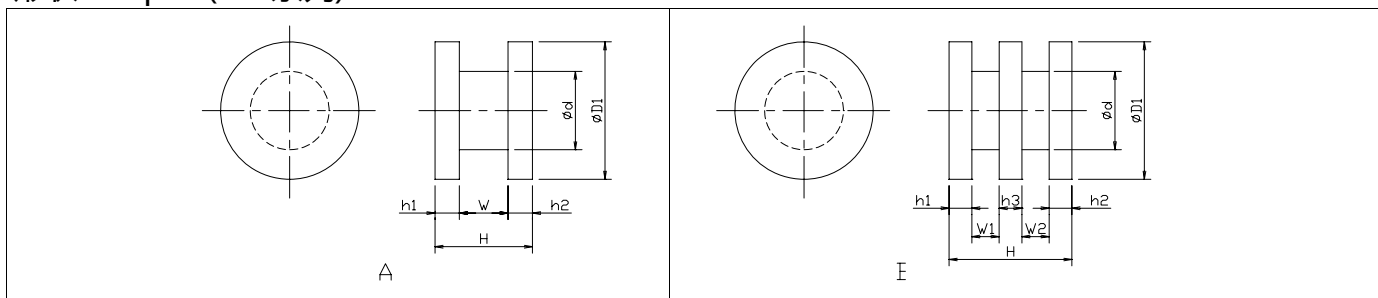

尺寸表 Dimensions(for example)

单位Unit: mm

品名	ΦD1	Φd	H	h1	h2	h3	W(1)	W2	种类
B1411	1.4±0.05	0.6±0.05	1.14±0.05	0.18±0.05	0.18±0.05	/	0.78±0.05	/	A
B1412	1.4±0.05	0.65±0.05	1.2±0.05	0.25±0.05	0.25±0.05	/	0.7±0.05	/	A
B1509	1.5±0.05	0.6±0.05	0.88±0.05	0.34±0.05	0.34±0.05	/	0.2±0.04	/	A
B1412-3F	1.4±0.05	0.8±0.05	1.2±0.05	0.2±0.05	0.2±0.05	0.2±0.05	0.3±0.05	0.3±0.05	B
B1717	1.7±0.05	0.7±0.05	1.65±0.05	0.4±0.07	0.4±0.05	/	0.9±0.05	/	A
B1810-3F	1.75±0.05	1.0±0.05	1.0±0.05	0.18±0.05	0.18±0.05	0.18±0.05	0.23±0.05	0.23±0.05	B
B1813-3F	1.75±0.05	1.3±0.05	1.3±0.05	0.26±0.05	0.26±0.05	0.24±0.05	0.27±0.04	0.27±0.04	B
B1810	1.75±0.05	0.8±0.05	1.0±0.05	0.3±0.05	0.3±0.05	/	0.4±0.05	/	A
B1815A	1.75±0.05	0.75±0.05	1.45±0.05	0.3±0.05	0.3±0.05	/	0.85±0.05	/	A
B1816	1.8±0.05	0.75±0.05	1.55±0.05	0.25±0.05	0.25±0.05	/	1.05±0.05	/	A
B1819	1.75±0.05	0.75±0.05	1.85±0.05	0.35±0.05	0.35±0.05	/	1.15±0.05	/	A
B1921	1.87±0.05	0.8±0.05	2.1±0.05	(0.45±0.05)	(0.45±0.05)	/	1.2±0.05	/	A

工型磁芯 DRUM CORES

形状 Shapes(Ø2 系列)

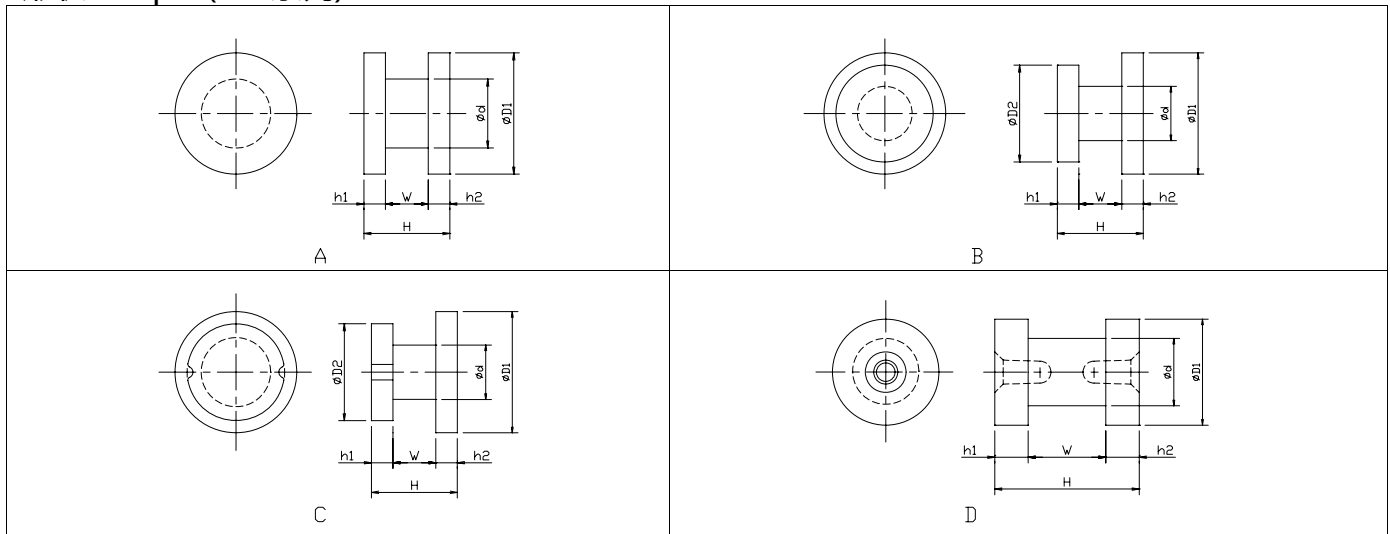

尺寸表 Dimensions(for example)

单位Unit: mm

品名	ΦD1	ΦD2	Φd	H	h1	h2	W	种类
B2009F	2.0±0.05	1.9±0.05	0.95±0.05	0.9±0.05	0.23±0.05	0.23±0.05	0.44±0.05	C
B2011SF	2.0±0.05	1.9±0.05	1.15±0.05	1.05±0.05	0.25±0.05	0.25±0.05	0.6±0.05	C(涂层)
B2308F	2.3±0.06	2.0±0.06	0.7±0.06	0.76±0.06	0.23±0.06	0.23±0.06	0.3±0.06	B
B2408	2.4±0.07	/	1.0±0.07	0.75±0.05	0.26±0.1	0.26±0.1	0.23±0.1	A
B2427A(B)	2.44±0.06	/	1.1±0.06	2.7±0.07	0.7±0.07	0.7±0.07	(1.3±0.06)	A
B2545D	2.5±0.1	/	1.5±0.1	4.5+0/-0.2	(0.85)	(0.7±0.07)	2.7±0.1	D
B2610SF	2.6±0.05	1.9±0.03	0.9±0.03	0.95±0.03	0.2±0.03	0.2±0.03	0.55±0.03	C
B2611	2.6±0.05	/	1.4±0.05	1.1±0.05	0.275±0.06	0.275±0.06	0.55±0.05	A
B2612	2.6±0.05	/	1.4±0.05	1.15±0.05	0.3±0.06	0.3±0.06	0.55±0.05	A
B2808	2.8±0.07	/	1.2±0.07	0.84±0.05	(0.27)	(0.27)	0.3±0.07	A
B2809	2.8±0.01	/	1.2±0.1	0.9±0.1	0.25±0.1	0.25±0.1	0.4±0.1	A
B2810	2.8±0.05	/	1.2±0.05	0.95±0.05	(0.325)	(0.325)	0.3±0.05	A
B2811	2.8±0.1	/	1.2±0.1	1.1±0.1	0.3±0.1	0.3±0.1	0.5±0.1	A
B2813	2.8±0.1	/	1.2±0.1	1.3±0.1	0.3±0.1	0.3±0.1	0.7±0.1	A
B2909	2.9±0.03	/	1.1±0.05	0.88±0.05	0.265±0.05	0.265±0.05	0.35±0.05	A
B2912	2.9±0.05	/	1.1±0.05	1.2±0.05	0.32±0.05	0.32±0.05	0.56±0.05	A

工型磁芯 DRUM CORES

形状 Shapes(Ø3系列)

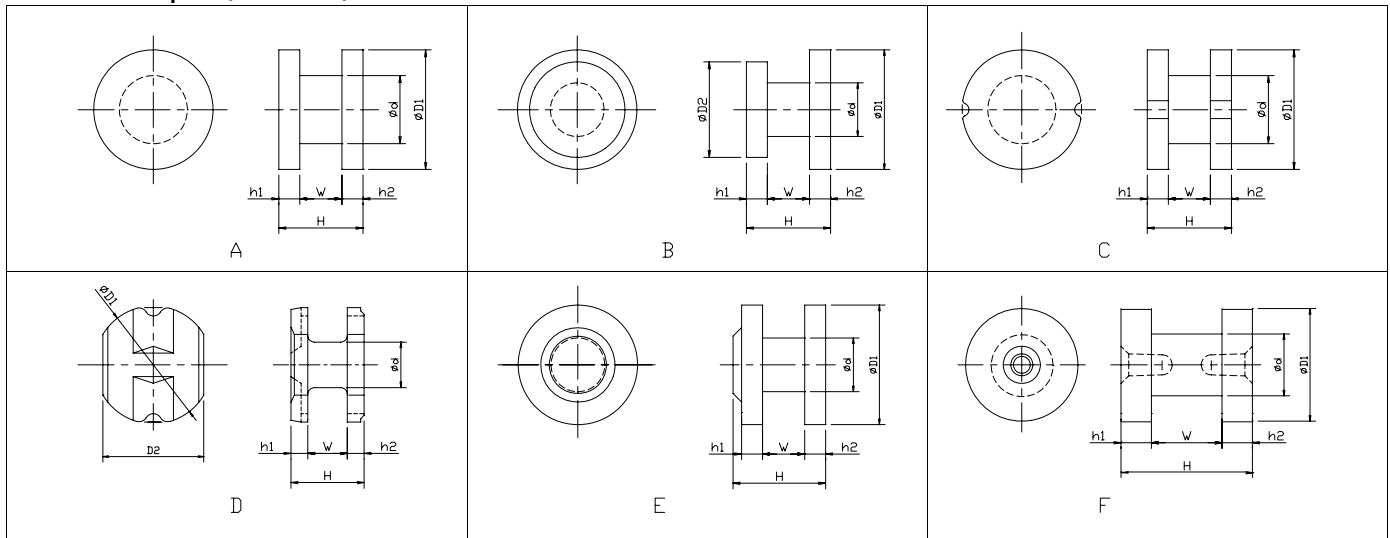

尺寸表 Dimensions(for example)

单位Unit: mm

品名	ΦD1	ΦD2	Φd	H	h1	h2	W	种类
B3010	3.0±0.06	/	1.4±0.1	1.0±0.06	0.3±0.1	0.3±0.1	0.4±0.1	A
B3011F	3.0±0.05	2.6±0.05	1.32±0.05	1.1±0.05	0.33±0.07	0.33±0.05	0.44±0.05	B
B3012	3.0±0.06	/	1.4±0.1	1.2±0.06	0.3±0.1	0.3±0.1	0.6±0.1	A
B3013F	3.0±0.05	2.6±0.05	1.32±0.05	1.3±0.05	0.33±0.07	0.33±0.05	0.64±0.05	B
B3040	3.0±0.1	/	1.4±0.1	4.0±0.1	0.9±0.1	0.9±0.1	2.2±0.1	A
B3060H	3.0±0.1	/	2.0±0.1	6.0±0.2	(1.45)	(1.45)	3+0.3/-0.1	F
B3060C	3.0±0.1	/	2.0±0.1	6.0±0.2	(1.15)	(1.15)	3.7±0.2	F
B3213	3.2±0.1	/	1.4±0.1	1.3±0.07	(0.35)	(0.35)	0.6±0.07	A
B3214S	3.15±0.04	/	1.45±0.05	1.35±0.05	0.28±0.05	0.28±0.05	0.79±0.05	C
B3233A	3.2±0.07	/	1.2±0.07	(3.22)	0.8±0.1	0.8±0.1	1.4±0.1	E
B3233B	3.2±0.07	/	1.2±0.07	(3.22)	0.7±0.1	0.7±0.1	1.6±0.1	E
B3313	3.3±0.07	/	1.4±0.07	1.3±0.07	0.375±0.07	0.375±0.07	0.55±0.07	A
B3516	3.5±0.1	/	1.1±0.1	1.6±0.1	0.43±0.1	0.43±0.1	0.74±0.1	A
B3516S	3.5±0.15	3.0±0.1	1.4±0.1	1.6±0.1	0.5±0.1	0.5±0.1	0.6±0.1	D
B3521SA	3.5±0.15	3.0±0.1	1.2±0.1	2.1±0.15	0.6±0.1	0.4±0.1	1.1±0.1	D
B3608	3.6±0.05	/	1.4±0.08	0.8±0.08	0.25±0.05	0.25±0.05	0.3±0.05	A
B3610	3.6±0.05	/	1.4±0.08	1.0±0.08	0.35±0.06	0.35±0.06	0.3±0.06	A
B3613	3.6±0.05	/	1.4±0.08	1.3±0.08	0.4±0.08	0.4±0.08	0.5±0.08	A
B3617A	3.6±0.05	/	1.4±0.08	1.7±0.08	0.45±0.08	0.45±0.08	0.8±0.08	A
B3909	3.9±0.1	/	2.0±0.1	0.93±0.05	(0.25)	(0.25)	0.43±0.05	A
B3913A	3.9±0.1	/	2.0±0.1	1.33±0.05	(0.315)	(0.315)	0.7±0.05	A
B3913B	3.9±0.1	/	1.6±0.1	1.33±0.05	(0.315)	(0.315)	0.7±0.05	A
B3918	3.9±0.1	/	2.0±0.1	1.83±0.05	(0.375)	(0.375)	1.08±0.05	A
B3918A	3.9±0.1	/	1.8±0.1	1.83±0.05	(0.375)	(0.375)	1.08±0.05	A

工型磁芯 DRUM CORES

形状 Shapes(Ø4系列)

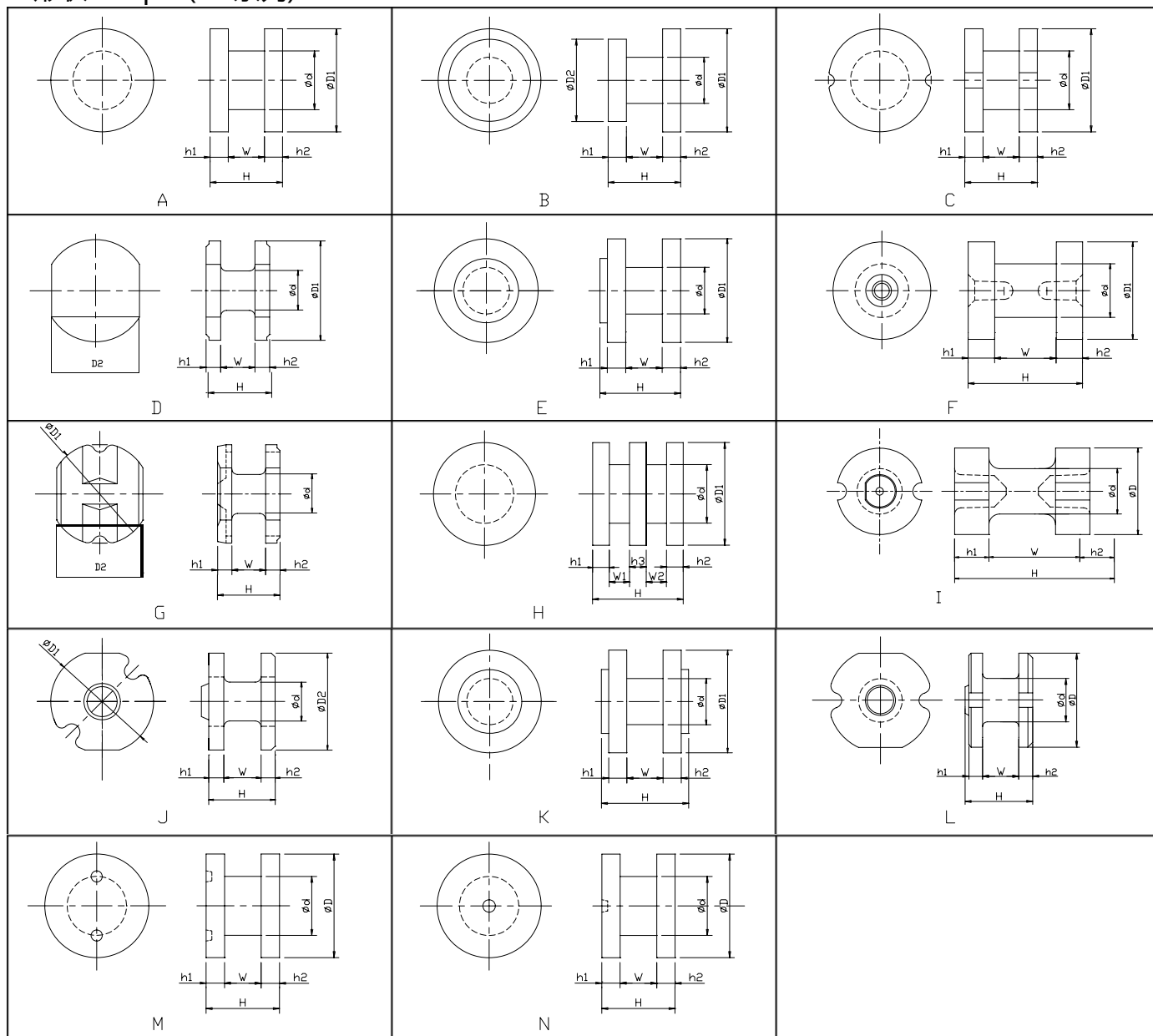

尺寸表 Dimensions(for example)

单位 Unit: mm

品名	ΦD1	ΦD2	Φd	H	h1	h2	h3	W(1)	W2	种类
B4009	4.0±0.05	/	1.8±0.05	0.9±0.05	0.3±0.05	0.3±0.05	/	0.3±0.05	/	A
B40100S	4.0±0.15	/	2.1+0.3/+0	10.0±0.3	1.6±0.2	1.6±0.2	/	6.8±0.3	/	I
B4015	4.0±0.05	/	1.8±0.05	1.5±0.05	0.3±0.05	0.3±0.05	/	0.9±0.05	/	A
B4018	4.0±0.1	/	1.7±0.12	1.8±0.12	0.35±0.1	0.45±0.1	/	0.75±0.1	/	E
B4024	4.0+0/-0.2	/	1.5±0.1	2.4±0.15	0.75±0.1	0.75±0.1	/	0.9±0.1	/	A
B4026-3F	4.0+0/-0.2	/	1.5±0.1	2.6±0.15	0.6±0.1	0.6±0.1	0.5±0.07	0.45±0.1	0.45±0.1	H
B4028	4.0±0.1	/	1.7±0.1	2.8±0.15	0.4±0.1	0.55±0.1	/	1.6±0.12	/	E
B4030	4.0±0.1	/	1.8±0.1	3.0±0.1	(0.8)	(0.8)	/	1.4±0.075	/	F
B4036(A, C)	4.0+0/-0.2	/	2.0±0.1	3.6±0.1	(0.75)	(0.75)	/	2.1±0.1	/	A

I型磁芯 DRUM CORES

品名	ΦD1	ΦD2	Φd	H	h1	h2	h3	W(1)	W2	种类
B4042	4.0+0/-0.1	/	2.0±0.1	4.2±0.1	(0.775)	(0.775)	/	2.65±0.1	/	A
B4045(A)	4.0+0/-0.2	/	2.0±0.1	4.5±0.15	1.1±0.15	1.1±0.15	/	2.3±0.15	/	A
B4045OSC	4.0+0/-0.2	/	1.6±0.1	4.5±0.15	1.6±0.15	1.6±0.15	/	1.3±0.15	/	A
B4060W-1	4.0±0.2	/	2.0±0.15	6.0±0.2	1.85±0.2	1.85±0.2	/	2.3±0.15	/	M
B4112F	4.1±0.1	3.2±0.1	1.4±0.1	1.2±0.1	0.3±0.1	0.3±0.1	/	0.6±0.1	/	B
B4209	4.2±0.03	/	1.6±0.05	0.88±0.05	0.27±0.05	0.27±0.05	/	0.34±0.05	/	A
B4210A	4.2+0/-0.1	/	2.1±0.07	0.97+0/-0.12	(0.305)	(0.305)	/	0.25+0.1/-0	/	A
B4210F	4.2±0.1	3.7±0.1	1.8±0.1	0.95±0.07	0.28±0.07	0.28±0.07	/	0.4±0.07	/	B
B4210FU	4.2±0.05	3.6±0.05	1.75±0.04	0.9±0.04	0.28±0.04	0.28±0.04	/	0.34±0.04	/	B
B4212(A、B)	4.2+0/-0.1	/	2.1±0.07	1.17+0/-0.12	(0.355)	(0.355)	/	0.4±0.05	/	A
B4216	4.2±0.1	/	1.7±0.12	1.6±0.12	0.35±0.1	0.45±0.1	/	0.55±0.10	/	E
B4218	4.2+0/-0.1	/	2.1±0.07	1.75+0/-0.12	(0.505)	(0.505)	/	0.68±0.05	/	A
B4328SA(SB)	4.3±0.1	3.9+0.05/-0.1	1.8±0.12	2.8±0.1	0.575±0.1	0.575±0.1	/	1.5±0.1	/	L
B4508	4.5±0.05	4.1±0.05	2.4±0.05	0.8±0.05	(0.25)	(0.25)	/	0.3+0.05/-0.02	/	D
B4512	4.5+0/-0.1	/	2.3±0.07	1.17+0/-0.12	(0.355)	(0.355)	/	0.4±0.05	/	A
B4512S	4.5±0.1	/	1.5±0.1	1.2±0.1	(0.35)	(0.35)	/	0.5±0.1	/	C
B4516	4.5±0.1	/	1.6±0.1	1.6±0.1	0.43±0.1	0.43±0.1	/	0.74±0.1	/	A
B4525B	4.5±0.1	/	1.8±0.1	2.5±0.1	0.55±0.1	0.55±0.1	/	1.4±0.1	/	A
B4532SA(SB、SC)	4.5±0.15	4.0±0.15	1.8±0.15	3.2±0.15	1.1±0.15	0.6±0.15	/	1.5±0.15	/	G
B4532SE	4.5±0.15	/	2.2±0.15	3.2±0.15	0.55±0.1	0.55±0.1	/	2.1±0.15	/	C
B4568S	4.5±0.1	/	1.8±0.1	6.7+0.2/-0.1	1.1±0.15	1.1±0.15	/	4.4+0.3/-0	/	C
B4590A	4.5±0.1	/	2.7±0.2	9.0±0.3	(1.5)	(1.5)	/	6.0±0.2	/	F
B4590D	4.5±0.1	/	2.4+0.2/-0	9.0±0.3	(1.2)	(1.2)	/	6.6±0.2	/	F
B4664	4.6+0/-0.15	/	2.0±0.1	6.4±0.2	1.0±0.1	1.0±0.1	/	3.8±0.1	/	E
B4672S	4.6+0/-0.15	/	2.2±0.15	7.2±0.15	0.95±0.15	0.9±0.15	/	5.3±0.15	/	C
B4672SA	4.6+0.05/-0.2	/	2.25±0.15	7.15±0.2	1.0±0.15	1.0±0.15	/	5.15±0.2	/	C
B4710	4.7+0/-0.15	/	2.0±0.07	1.0±0.1	(0.3)	(0.3)	/	0.4±0.07	/	A
B4716	4.7+0/-0.15	/	1.6±0.07	1.6±0.1	(0.4)	(0.4)	/	0.8±0.07	/	A
B4722	4.7+0/-0.15	/	2.0±0.07	2.2±0.1	(0.4)	(0.4)	/	1.4±0.07	/	A
B4723	4.7+0/-0.15	/	2.0±0.07	2.3±0.1	(0.5)	(0.5)	/	1.3±0.07	/	A
B4725	4.7+0/-0.15	/	1.5+0/-0.15	2.5±0.1	0.6±0.07	0.6±0.07	/	1.3±0.07	/	K
B4727	4.7+0/-0.15	/	2.0±0.07	2.7±0.1	(0.4)	(0.4)	/	1.9±0.07	/	A
B4728	4.7+0/-0.15	/	1.8+0/-0.15	2.8±0.1	0.55±0.07	0.55±0.07	/	1.7+0.05/-0.1	/	K
B4730-3F	4.7+0/-0.15	/	1.8±0.07	3.0±0.1	(0.4)	(0.4)	0.6±0.1	0.8±0.1	0.8±0.1	H
B4819S	4.8±0.07	4.5±0.07	2.0±0.07	1.85±0.07	0.5±0.07	0.5±0.07	/	0.7±0.07	/	J
B4829S	4.8±0.06	4.5±0.06	1.92±0.06	2.9±0.06	0.55±0.06	0.55±0.06	/	1.65±0.06	/	J
B4840	4.8±0.1	/	2.7±0.1	4.0±0.1	0.7±0.1	0.7±0.1	/	2.6±0.1	/	N

工型磁芯 DRUM CORES

形状 Shapes(Ø5 系列)

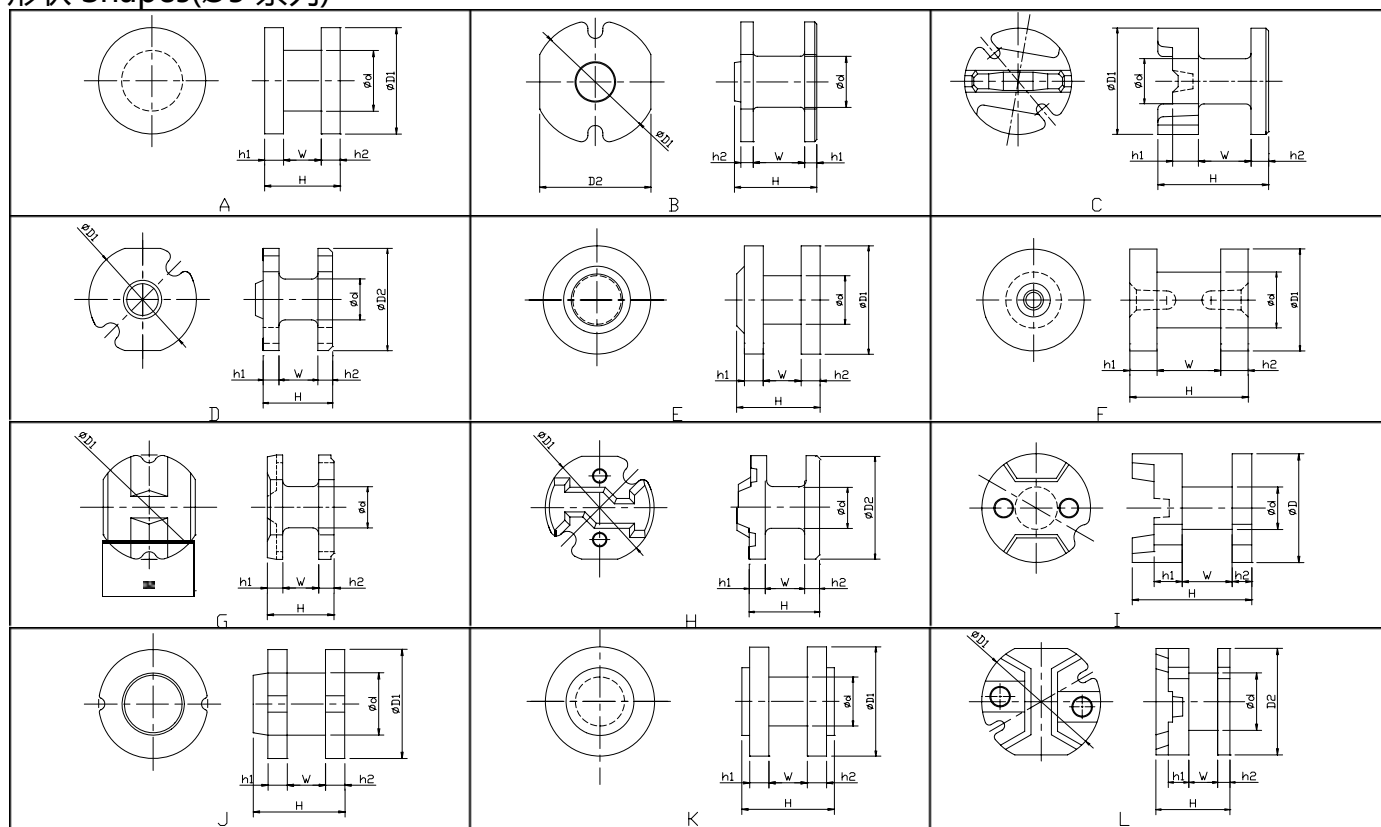

尺寸表 Dimensions(for example)

单位 Unit: mm

品名	$\Phi D1$	$D2$	Φd	H	$h1$	$h2$	W	种类
B5017	5.0 ± 0.1	/	1.8 ± 0.1	1.7 ± 0.07	0.45 ± 0.1	0.45 ± 0.1	0.8 ± 0.08	E
B5023	5.0 ± 0.1	/	1.9 ± 0.1	2.2 ± 0.05	0.54 ± 0.07	0.54 ± 0.07	1.12 ± 0.07	E
B5030	$4.9 + 0.05 / - 0.1$	/	$2.0 + 0.2 / - 0$	$3.0 + 0.2 / - 0.3$	0.75 ± 0.2	0.75 ± 0.2	1.5 ± 0.2	A
B5055S	5.0 ± 0.2	/	1.95 ± 0.1	5.5 ± 0.2	1.3 ± 0.15	0.9 ± 0.15	2.3 ± 0.15	I
B5063	$5.0 + 0 / - 0.15$	/	1.8 ± 0.1	6.85 ± 0.15	1.35 ± 0.1	0.9 ± 0.1	4.0 ± 0.1	J
B5331S	5.3 ± 0.15	5.0 ± 0.15	2.0 ± 0.15	3.1 ± 0.2	0.7 ± 0.15	0.6 ± 0.15	(1.2)	H
B5336(C)	5.3 ± 0.1	/	2.8 ± 0.1	3.6 ± 0.15	0.6 ± 0.1	0.6 ± 0.1	2.4 ± 0.12	A
B5343S	5.3 ± 0.15	5.0 ± 0.15	2.0 ± 0.15	4.3 ± 0.2	0.7 ± 0.15	0.6 ± 0.15	(2.4)	H
B5560A	5.5 ± 0.15	/	2.6 ± 0.1	6.0 ± 0.2	(1.25)	(1.25)	3.5 ± 0.2	F
B5590	5.5 ± 0.15	/	$3.5 + 0.2 / - 0$	6.0 ± 0.2	(1.25)	(1.25)	3.5 ± 0.2	F
B5626	5.6 ± 0.1	/	2.4 ± 0.1	2.6 ± 0.05	0.65 ± 0.1	0.65 ± 0.1	1.05 ± 0.1	E
B5820SA	5.8 ± 0.2	5.2 ± 0.2	2.6 ± 0.1	2.0 ± 0.07	0.9 ± 0.1	0.55 ± 0.1	0.55 ± 0.1	G
B5824S	5.8 ± 0.07	5.5 ± 0.07	2.3 ± 0.07	2.35 ± 0.07	0.55 ± 0.07	0.55 ± 0.07	1.0 ± 0.07	D
B5827S	5.8 ± 0.07	5.5 ± 0.07	2.3 ± 0.07	2.65 ± 0.1	0.55 ± 0.07	0.55 ± 0.07	1.3 ± 0.07	D
B5836S	5.8 ± 0.1	5.2 ± 0.1	2.8 ± 0.1	3.6 ± 0.1	1.0 ± 0.1	0.6 ± 0.1	1.4 ± 0.1	L
B5839S	5.8 ± 0.15	5.2 ± 0.15	2.4 ± 0.15	3.85 ± 0.15	0.575 ± 0.1	0.575 ± 0.1	2.4 ± 0.1	B
B5845SA	5.8 ± 0.15	5.2 ± 0.2	2.4 ± 0.15	4.5 ± 0.2	1.2 ± 0.15	0.8 ± 0.15	2.5 ± 0.15	G
B5860S(SA)	5.8 ± 0.1	/	2.2 ± 0.1	6.2 ± 0.15	1.4 ± 0.1	1.1 ± 0.1	2.9 ± 0.15	C
B5917	5.9 ± 0.08	/	2.5 ± 0.1	$1.73 + 0 / - 0.12$	(0.45)	(0.45)	0.77 ± 0.07	K
B5919	5.9 ± 0.08	/	2.5 ± 0.1	1.85 ± 0.06	(0.45)	(0.45)	0.89 ± 0.07	K
B5921	5.9 ± 0.08	/	2.5 ± 0.1	$2.1 + 0 / - 0.12$	(0.47)	(0.47)	1.2 ± 0.07	K
B5922	5.9 ± 0.08	/	2.5 ± 0.05	$2.16 + 0.03 / - 0$	0.43 ± 0.02	0.43 ± 0.02	$1.09 + 0.05 / - 0$	K
B5928	5.9 ± 0.08	/	2.5 ± 0.1	$2.8 + 0 / - 0.12$	(0.4)	(0.4)	1.8 ± 0.07	K

工型磁芯 DRUM CORES

形状 Shapes(Ø6 系列)

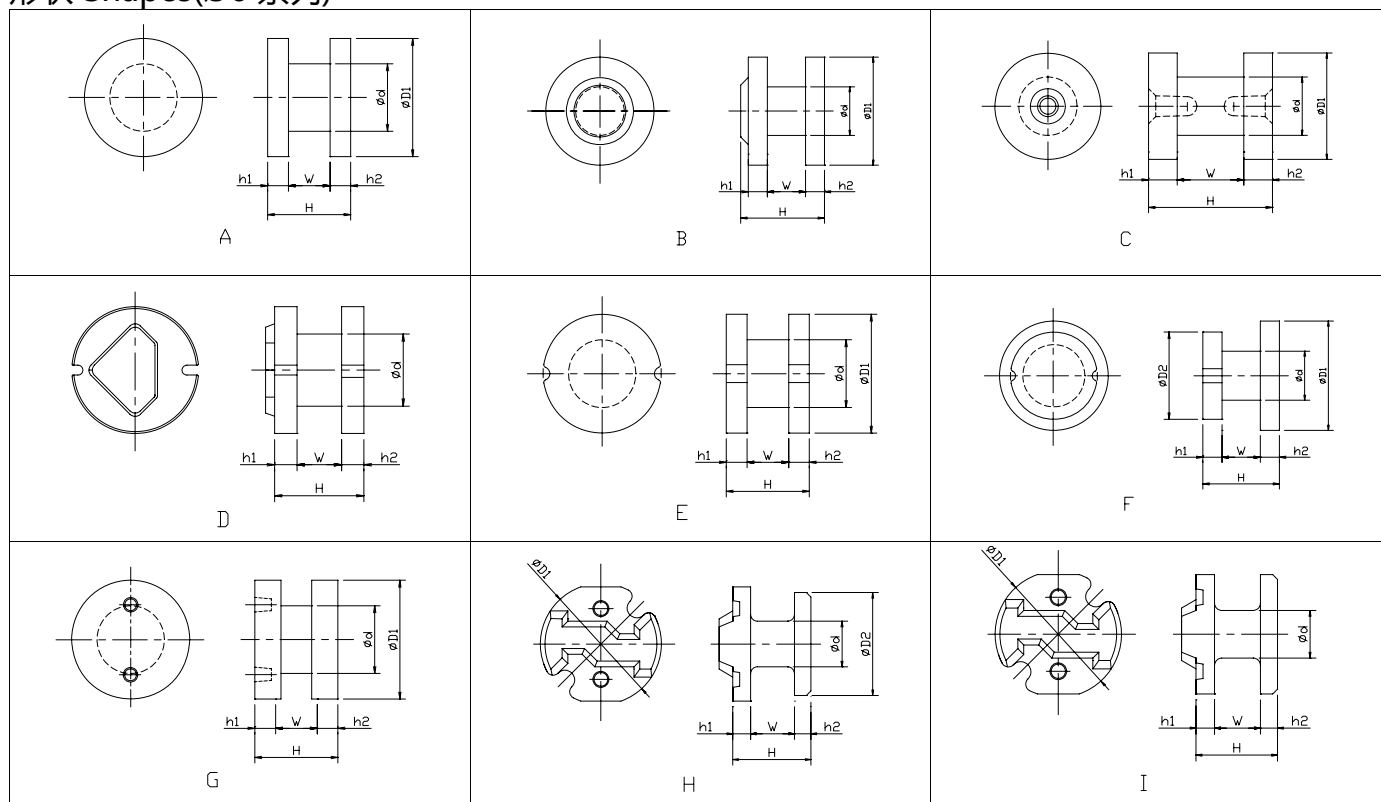

尺寸表 Dimensions(for example)

单位Unit: mm

品名	ØD1	ØD2	Ød	H	h1	h2	W	种类
B6008	6.0±0.08	/	4.0±0.08	0.75+0.1/-0.05	0.24±0.07	0.24±0.07	0.3±0.07	A
B6043	6.0+0.08/-0.1	/	2.2±0.1	(4.3)	0.87±0.1	0.57±0.1	2.36±0.1	B
B6044S	6.0±0.15	/	2.65+0.3/-0.05	4.4±0.15	0.95±0.15	0.95±0.15	2.5±0.15	E
B6070A(B)	5.8±0.15	/	2.5±0.1	7.0±0.25	1.5±0.15	1.5±0.15	4.0±0.15	A
B6075(W)	6.0±0.3	/	2.4±0.2	7.5±0.3	2.25±0.2	2.25±0.2	3.0±0.25	G
B6080S	6.0±0.15	/	3.0±0.15	8.0±0.25	1.8±0.2	1.8±0.2	4.4±0.2	E
B6080SA	6.0±0.15	/	2.5±0.15	8.0±0.25	1.8±0.2	1.8±0.2	4.4±0.2	E
B60100(A)	6.0±0.15	/	3.0±0.2	10.0±0.2	1.55±0.15	1.55±0.15	6.9±0.2	A
B6265	6.2+0/-0.15	/	2.5±0.15	6.5±0.15	1.5±0.15	1.0±0.15	4.0±0.15	A
B6590	6.5±0.1	/	3.7+0.2/+0	9.0±0.3	1.5±0.2	1.5±0.2	6.0±0.2	C
B6641SF	6.6±0.1	5.3±0.1	3.4±0.15	4.1±0.15	0.75±0.1	0.75±0.1	2.6±0.1	F
B6826	6.8±0.1	/	2.3±0.1	2.6±0.12	0.7±0.1	0.7±0.1	1.2±0.1	A
B6827S	6.8±0.1	/	3.2±0.1	2.65±0.1	0.58±0.1	0.58±0.1	1.24±0.1	D
B6829S	6.8±0.2	/	2.3±0.15	2.9±0.2	0.7±0.15	0.6±0.15	(1.0)	I
B6836S	6.8±0.2	/	2.8±0.15	3.6±0.2	0.7±0.15	0.7±0.15	(1.6)	I
B6838S	6.8±0.2	/	2.8±0.15	3.8±0.2	0.7±0.15	0.7±0.15	(1.8)	I
B6847SF	6.8±0.2	5.2+0/-0.15	2.9±0.1	4.7±0.2	0.8±0.15	0.7±0.15	(2.6)	H

工型磁芯 DRUM CORES

形状 Shapes(Ø7系列)

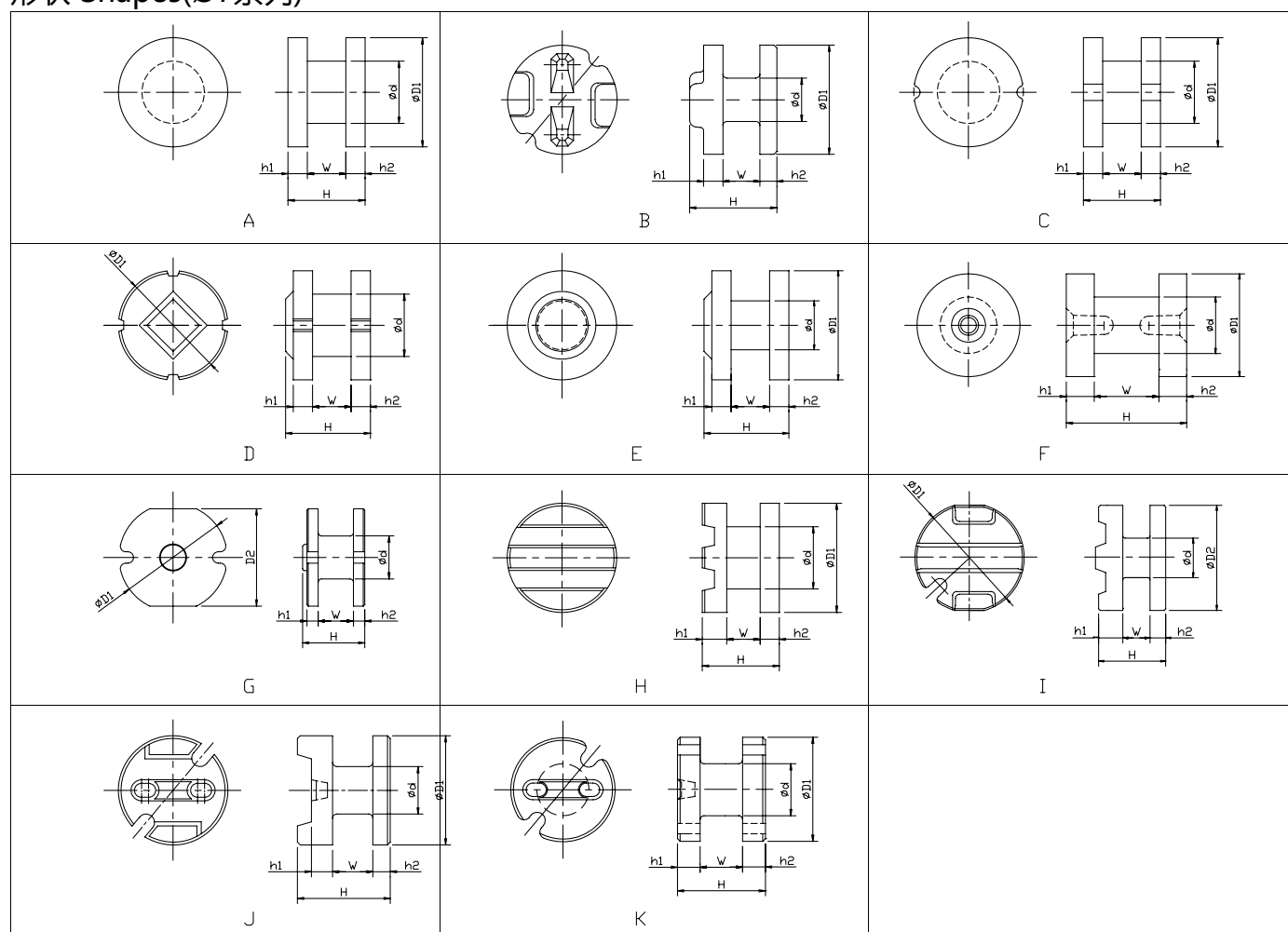

尺寸表 Dimensions(for example)

单位 Unit: mm

品名	ØD1	ØD2	Ød	H	h1	h2	W	种类
B7035	7.0±0.15	/	2.6±0.1	3.5±0.15	0.8±0.1	0.8±0.1	1.9±0.1	A
B7048	7.0±0.1	/	3.2±0.1	4.8±0.1	0.75±0.1	1.0±0.1	2.8±0.1	E
B7070S	7.0+0/-0.15	/	3.0+0/-0.2	7.0+0.1/-0.2	(1.0)	(1.0)	4.8+0.3/+0	C
B7549	7.5±0.1	/	3.0±0.1	4.9±0.15	0.5±0.1	0.9±0.1	3.1±0.15	E
B7569	7.5±0.1	/	3.4±0.1	6.9±0.1	0.5±0.1	0.9±0.1	5.1±0.1	E
B7574S	7.5±0.1	/	3.2±0.1	7.4+0.1/-0.15	1.1±0.1	1.5±0.1	4.4±0.1	D
B7585	7.5±0.1	/	4.5±0.1	8.5±0.1	0.7±0.1	1.1±0.1	6.3±0.1	E
B7590	7.5±0.1	/	3.8+0.2/+0	9±0.3	(1.5)	(1.5)	6.0±0.2	F
B7744S	7.65±0.15	6.9±0.15	3.05+0.2/-0.15	4.4±0.15	0.8±0.1	0.8±0.1	2.5±0.1	G
B7829S	7.8±0.15	7.5±0.2	2.8±0.15	2.9±0.15	1.4±0.15	0.65±0.15	0.85±0.15	I
B7835	7.8±0.2	/	3.0±0.1	3.5±0.2	1.55±0.15	0.65±0.15	1.3±0.15	H
B7846S	7.8±0.2	7.5±0.2	3.1±0.15	4.6±0.2	1.55±0.15	0.8±0.15	2.25±0.15	I
B7847	7.8±0.2	/	3.0±0.2	4.7±0.2	1.6±0.15	0.8±0.15	2.3±0.15	H
B7847A	7.8±0.2	/	3.3±0.1	4.7±0.2	1.6±0.15	0.8±0.15	2.3±0.15	H
B7851S	7.8±0.2	/	3.4±0.15	5.1±0.2	1.7±0.2	0.9±0.1	1.5±0.15	J
B7852S	7.8±0.15	/	3.1±0.15	5.2±0.2	1.8±0.15	1±0.15	1.4±0.15	B

工型磁芯 DRUM CORES

品名	$\Phi D1$	$\Phi D2$	Φd	H	h1	h2	W	种类
B7870SC(SD)	7.8±0.2	/	3.4±0.15	7.0±0.2	1.7±0.2	0.9±0.15	3.4±0.15	J
B7880S	7.8±0.15	/	3.0±0.1	8.0±0.2	1.5±0.12	1.5±0.12	5.0±0.15	C
B7888S	7.8±0.2	/	3.4±0.15	8.8±0.2	1.7±0.15	1.7±0.15	5.4±0.15	K
B7888S-1	7.8±0.2	/	3.7±0.15	8.8±0.2	1.7±0.15	1.7±0.15	5.4±0.15	K
B7890S(A~D)	7.8±0.2	/	3.6±0.15	9.0±0.2	1.7±0.2	0.9±0.15	5.4±0.15	J
B7892S	7.8±0.15	/	3.0±0.15	9.2±0.2	1.8±0.15	1.2±0.15	5.2±0.15	B
B7949	7.9±0.1	/	3.25±0.1	4.9±0.12	(0.8)	(0.8)	3.3±0.1	A
B7970S	7.9±0.15	/	3.0±0.12	7.0±0.2	(1.5±0.2)	(1.5±0.2)	4.0±0.15	C
B79100S	7.9±0.2	/	2.85±0.1	10.0±0.2	2.0±0.2	2.0±0.2	6.0±0.3	C
B79130S	7.9±0.15	/	3.3±0.12	13.0±0.2	2.0±0.2	2.0±0.2	9.0±0.3	C

工型磁芯 DRUM CORES

形状 Shapes(Ø8 系列)

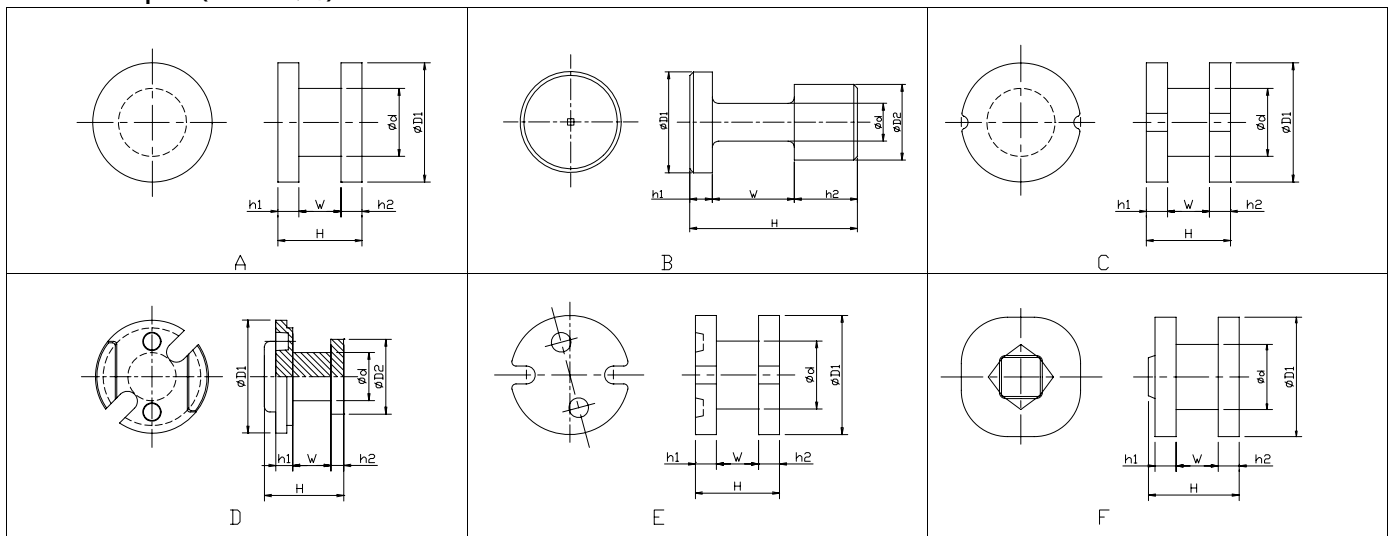

尺寸表 Dimensions(for example)

单位Unit: mm

品名	$\Phi D1$	$\Phi D2$	Φd	H	$h1$	$h2$	W	种类
B8040	$7.8+0.1/-0.2$	/	3.0 ± 0.2	$4.0+0/-0.5$	1.25 ± 0.2	1.25 ± 0.2	1.5 ± 0.3	A
B8056SF	$8+0/-0.25$	$5.3+0.05/-0.2$	$3.5+0.15/-0.1$	$5.6+0/-0.3$	(2.0)	0.9 ± 0.12	2.7 ± 0.12	D
B8070(W)	8.0 ± 0.3	/	3.0 ± 0.2	7.0 ± 0.2	1.8 ± 0.2	1.8 ± 0.2	3.4 ± 0.2	A
B8080A(B)	8.0 ± 0.2	/	3.0 ± 0.15	8.0 ± 0.3	2.0 ± 0.15	2.0 ± 0.15	(4.0)	A
B80100A(B,C)	8.0 ± 0.2	/	3.0 ± 0.25	10.0 ± 0.25	2.0 ± 0.15	2.0 ± 0.15	6.0 ± 0.2	A
B80100D	8.0 ± 0.2	/	2.5 ± 0.15	10.0 ± 0.2	(1.5)	(1.5)	7.0 ± 0.2	A
B80100S	8.0 ± 0.15	/	3.0 ± 0.12	10.0 ± 0.2	2.2 ± 0.2	2.2 ± 0.2	5.6 ± 0.3	C
B80100SA	8.0 ± 0.15	/	4.0 ± 0.12	10.0 ± 0.2	2.0 ± 0.15	2.0 ± 0.15	6.0 ± 0.2	E
B80100SW	8.0 ± 0.15	/	3.0 ± 0.12	10.0 ± 0.2	2.2 ± 0.3	2.2 ± 0.3	5.6 ± 0.3	E
B80133Z	8.0 ± 0.2	6.0 ± 0.15	3.0 ± 0.15	13.3 ± 0.3	1.8 ± 0.2	5.0 ± 0.2	6.5 ± 0.2	B
B8426	$8.4+0/-0.2$	/	3.9 ± 0.08	$2.6+0/-0.16$	(0.7)	(0.7)	1.2 ± 0.08	A
B8427	8.4 ± 0.1	/	3.18 ± 0.05	(2.65)	0.7 ± 0.1	0.7 ± 0.1	1.0 ± 0.12	F
B8440	8.4 ± 0.1	/	3.5 ± 0.1	4.0 ± 0.1	0.7 ± 0.1	0.7 ± 0.1	2.6 ± 0.1	A

工型磁芯 DRUM CORES

形状 Shapes(Ø9系列)

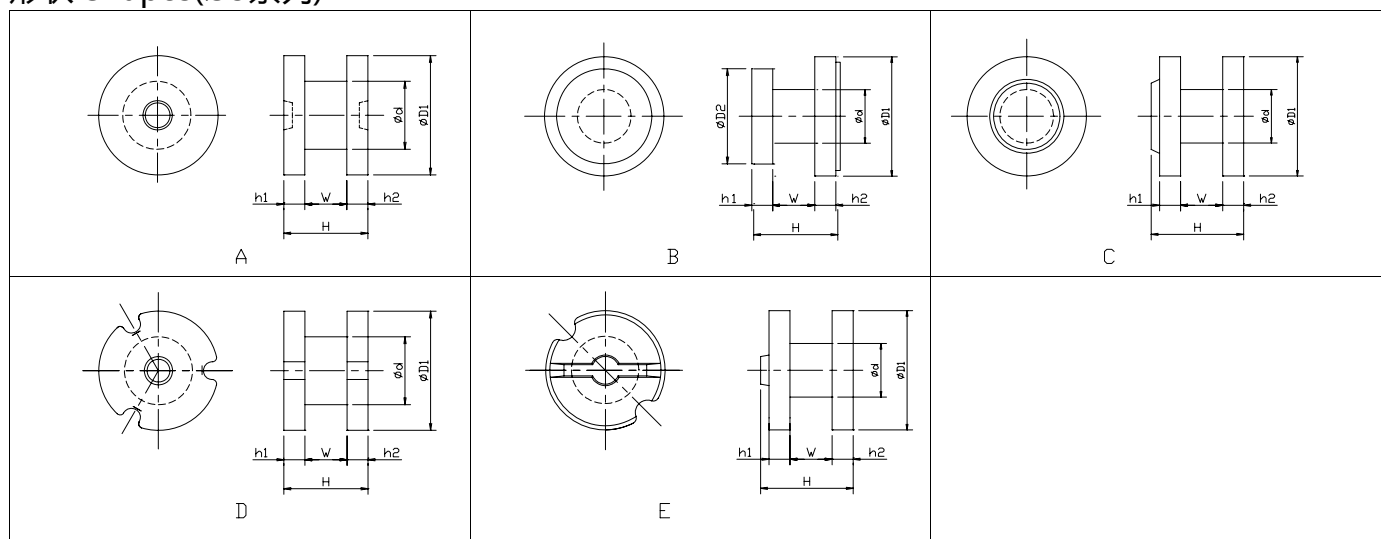

尺寸表 Dimensions(for example)

单位Unit: mm

品名	ΦD1	ΦD2	Φd	H	h1	h2	W	种类
B9040S	9+0.05/-0.15	/	3.6±0.15	4.0±0.15	1.05±0.15	1.05±0.15	1.9±0.15	D
B9046	9.0±0.1	/	3.8±0.1	(4.60)	0.75±0.1	0.75±0.1	2.7±0.15	C
B9059	9.0±0.15	/	5.0±0.1	5.9±0.15	0.7±0.15	1.2±0.15	3.5±0.15	C
B9059F	9.0±0.15	6.4±0.15	4.0±0.1	5.9±0.15	1.2±0.1	1.2±0.1	3.5±0.1	B
B90100	9+0.05/-0.15	/	7.0±0.12	10.0±0.2	1.75±0.12	1.75±0.12	6.5±0.15	A
B9633S	9.6±0.15	/	4.0±0.1	3.3±0.2	(0.8±0.1)	1.05±0.1	(1.2)	E
B9645S	9.6±0.15	/	4.0±0.1	4.5±0.2	(0.8±0.1)	1.05±0.1	(2.4)	E

工型磁芯 DRUM CORES

形状 Shapes(Ø10 及以上系列)

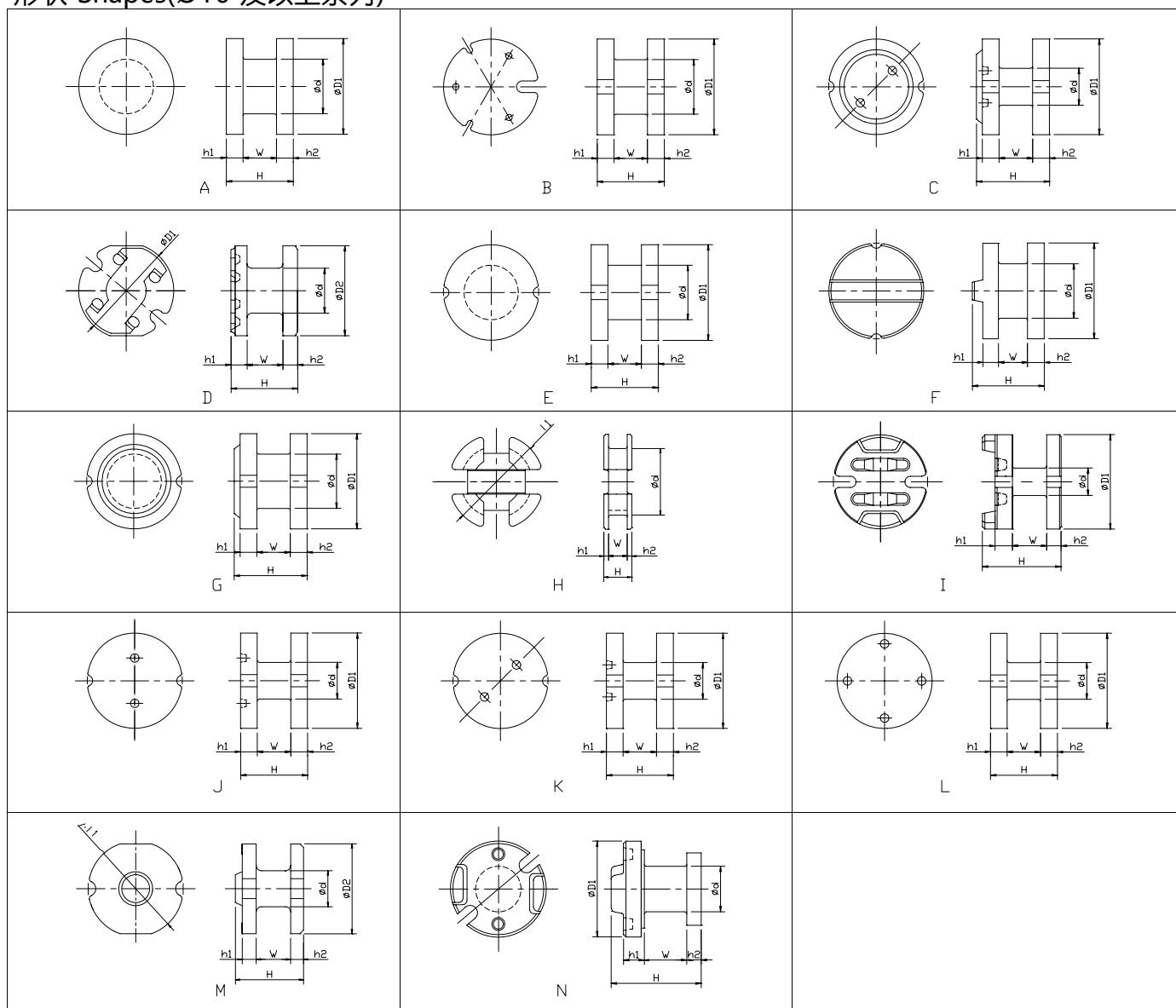

尺寸表 Dimensions(for example)

单位 Unit: mm

品名	$\Phi D1$	$\Phi D2$	Φd	H	h1	h2	W	种类
B10032	10.0+0/-0.2	/	4.0±0.15	3.2±0.15	1.0±0.15	1.0±0.15	1.2±0.15	A
B10032S	10.0±0.15	9.4±0.15	(3.55)	3.2±0.1	1.15±0.1	0.85±0.1	1.2±0.1	D
B10034S	10.0±0.12	/	4.0±0.15	3.35+0.1/-0.15	0.85±0.1	0.85±0.1	1.4±0.1	G
B10036S	10.0±0.15	/	3.5±0.15	3.6±0.15	0.55±0.15	0.55±0.15	(1.7)	F
B10037S	10.0±0.15	9.4±0.15	(3.85)	3.7±0.1	1.2±0.1	1.0±0.1	1.5±0.1	D
B10038	9.9±0.1	/	4.3±0.1	3.8±0.1	0.9±0.1	0.9±0.1	2.0±0.1	A
B10039B	10.0+0.2/-0.1	/	3.8±0.15	3.9±0.2	1.1±0.15	1.1±0.15	1.7±0.2	A
B10041SA	10.0±0.15	/	3.5±0.15	4.1±0.15	0.95±0.15	0.95±0.15	(1.4)	F
B10047S	10.0±0.15	9.4±0.15	3.85±0.1	4.7±0.1	1.2±0.1	1.2±0.1	2.3±0.1	D
B10047SA	10.0±0.15	8.9±0.15	4.0±0.15	4.7±0.15	1.0±0.1	1.0±0.1	2.4±0.1	M
B10061S	10.0±0.15	/	3.8±0.15	6.1±0.2	2.0±0.12	1.3±0.1	1.7±0.15	I

工型磁芯 DRUM CORES

品名	ΦD1	ΦD2	Φd	H	h1	h2	W	种类
B10071S	10.0±0.2	/	5.0±0.2	7.1±0.2	1.3±0.2	1.3±0.2	(3.7)	F
B10080	10.0±0.2	/	4.0±0.15	8.0±0.3	1.5±0.15	1.5±0.15	(5.0)	A
B10081S	10.0±0.12	/	3.9±0.12	8.1±0.2	2.0±0.12	1.3±0.1	3.7±0.15	I
B100100	10.0±0.2	/	3.2±0.15	10.0±0.3	1.5±0.15	1.5±0.15	(7.0)	A
B100100SB	10.0±0.2	/	4.5±0.2	10.0±0.2	2.0±0.2	2.0±0.2	6.0±0.2	C
B100101S	10.0±0.12	/	4.3±0.12	10.1±0.2	2.0±0.12	1.5±0.1	5.5±0.15	I
B100120	10.0±0.2	/	3.0±0.2	12.0±0.15	2.0±0.2	2.0±0.2	8.0±0.2	A
B100120A	10.0±0.2	/	3.2±0.2	12.0±0.3	2.0±0.2	2.0±0.2	8.0±0.2	A
B100120S	10.0±0.2	/	5.5±0.2	12.0±0.2	2.0±0.2	2.0±0.2	8.0±0.2	J
B100140ST	10.0±0.2	/	5.5±0.2	14.0±0.1/-0.2	2.25±0.2	2.25±0.2	(9.45)	C
B10228	10.2±0.1	/	3.5±0.15	2.8±0.1	0.8±0.1	0.8±0.1	1.0±0.4/-0	A
B10243(A)	10.2±0.1	/	3.7±0.15	4.3±0.1	0.8±0.1	0.8±0.1	2.7±0.12	A
B110140ST	11.0±0.2	/	6.0±0.2	14.0±0.1/-0.2	1.55±0.2	1.55±0.2	(9.4)	C
B110150S	11.0±0.3	/	5.0±0.5	15.0±0.3	2.25±0.3	2.25±0.1	10.5±0.2	K
B110150SD	11.0±0.2	/	5.5±0.2	15.0±0.2	1.55±0.2	2.25±0.2	(10.5)	C
B112100S	11.2±0.2	/	4.0±0.2	10.0±0.2	(2)	(2)	6.0±0.2	G
B12078SAW	12.0±0.2	/	4.5±0.15	7.8±0.15	1.7±0.12	1.7±0.12	3.4±0.15	N
B130110	13.0±0.3	/	4.5±0.15	11.0±0.2	2.05±0.3	2.05±0.3	6.9±0.2	A
B130115	13.0±0.2	/	4.8±0.2	11.5±0.3	2.5±0.2	2.5±0.2	6.5±0.3/-0	L
B130145	13.1±0.5	/	4.7±0.5	14.5±0.5	2.9±0.2	2.0±0.2	9.6±0.2	A
B140150S	14.0±0.2	/	5.7±0.2	15.0±0.3	3.0±0.2	3.0±0.2	9.0±0.25	B
B140160S	14.0±0.2	/	6.5±0.2	16.0±0.2	3.2±0.2	3.2±0.2	9.6±0.3	G
B140165S	14.0±0.3	/	7.2±0.2	16.5±0.5	3.0±0.2	3.0±0.2	10.5±0.3	G
B14426S	14.4±0.15	/	10.8±0.1	2.6±0.07	0.7±0.1	0.7±0.1	1.2±0.07	H
B150120	15.0±0.3	/	4.5±0.2	12.0±0.2	3.0±0.2	3.0±0.2	6.0±0.2	A
B150130	15.0±0.3	/	5.0±0.2	13.0±0.5	2.0±0.2	2.0±0.2	9.0±0.2	A
B150130S	15.0±0.3	/	6.0±0.2	13.0±0.2	2.0±0.2	2.0±0.2	9.0±0.3	G
B150135S	15.0±0.3	/	5.0±0.2	13.5±0.5	2.0±0.2	2.0±0.2	9.5±0.2	G
B150140(A)	15.0±0.2	/	4.75±0.2	14.0±0.3	2.25±0.2	2.25±0.2	9.5±0.3	A
B150145	15.0±0.3	/	6.5±0.3	14.5±0.3	2.5±0.2	2.5±0.2	9.5±0.3	A
B150155A(B,C)	15.0±0.3	/	5.0±0.3	15.5±0.3	2.5±0.2	(2.5)	10.5±0.3	A
B150160	15.0±0.3	/	5.5±0.15	16.0±0.3	2.5±0.2	2.5±0.2	11.0±0.3	A
B150160S	15.0±0.3	/	7.5±0.3	16.0±0.5	2.5±0.3	2.5±0.3	11.0±0.3	G
B150180SA	15.0±0.3	/	7.5±0.3	18.2±0.5	3.4±0.3	2.8±0.3	12.0±0.3	G
B180160	18.0±0.4	/	6.0±0.4	16.0±0.4	2.5±0.3	2.5±0.3	11.0±0.3	A
B180180(A)	18.0±0.4	/	8.5±0.4	18.0±0.4	2.5±0.3	2.5±0.3	13.0±0.4	A



形状 Shape

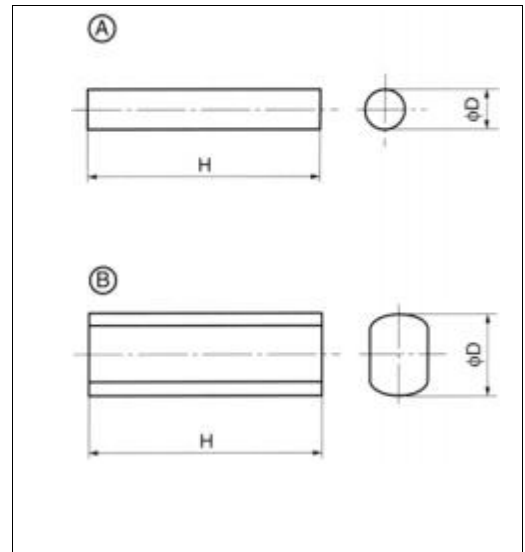

柱型磁芯的产品称呼有以下的命名，采用了以下的命名法
Naming of rod core models

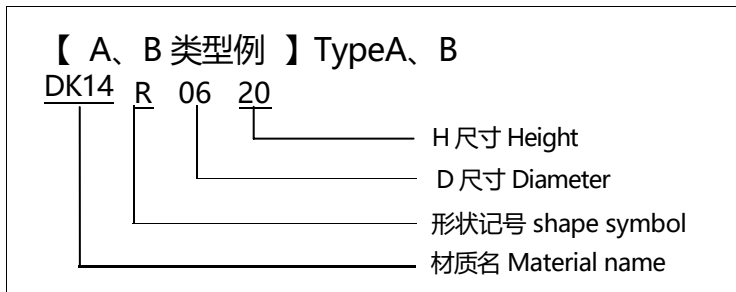

尺寸表 Dimensions(for example)

单位 Unit: mm

品名	ΦD	H	种类
R01811	1.8+0/-0.06	10.8+0/-0.15	A
R0316	3.0±0.3	16.0±0.3	A
R0412	4.0+0.1/-0.2	12.0±0.3	A
R0418	4.0+0/-0.3	17.9+0/-0.6	A
R0512	5.0±0.15	12.0±0.3	A
R0525	5.0+0/-0.3	25.0±0.5	A
R05515	5.5±0.15	15.0±0.6	A
R05521A	5.5±0.15	21.0±0.6	A
R0615	6.0±0.1	15.0+0.1/-0.3	B
R0619	6.0±0.15	19.0±0.6	A
R0620	6.0+0/-0.3	20.0±1.0	A
R0630	6.0+0.1/-0.2	30.0±1.0	A
R0642	6.0±0.2	42.0±0.4	B
R0738	7.0±0.2	38.0±0.5	B
R1007	10.0±0.2	7.0±0.3	A
R1018	10.0+0/-0.3	18.2±0.2	A
R1020	10.0±0.3	20.0±1.0	A
R1030	10.0±0.3	30.0+0/-2.0	A
R1107A	10.5±0.1	7.2±0.1	B

板条型磁芯 BATTEN CORES

形状 Shapes

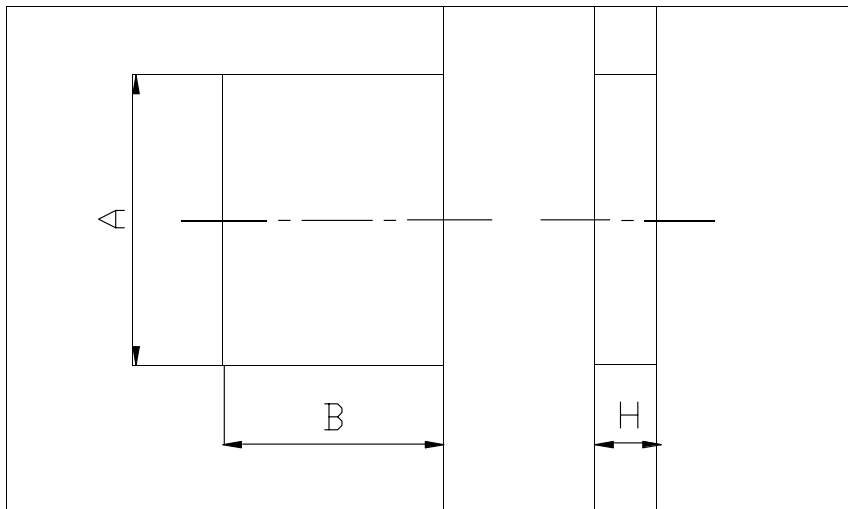

尺寸表 Dimensions(for example)

单位 Unit: mm

品名	A	B	H
2×1.2×0.3	1.95±0.05	1.15±0.05	0.33±0.04
4.8×3.8×1.4	4.8±0.1	3.8±0.1	1.4±0.1
6×2.5×7.5	6.0±0.2	2.5±0.1	7.5±0.3
10.5×6×2.9	10.5±0.3	6.0±0.3	2.9±0.1
12×5×1.5	12.0±0.2	5.0±0.15	1.5±0.1
12×6×3	12.0±0.2	6.0±0.1	3.0±0.1
15×4×2	15.0±0.2	4.0±0.2	2.0±0.1
18×4.7×2	18.0+0.05/-0.3	4.7±0.2	2.0+0.2/-0.13
20×4×2	20.0±0.3	4.0±0.2	2.0±0.1
20×10×24	20+0/-0.3	10+0/-0.3	24+0/-0.3
22.9×2.9×1.9	22.9±0.3	2.9±0.2	1.9±0.2
24×2×3.5	24.0±0.2	2.0+0.1/-0.05	3.5±0.1
24×4×2	24.0±0.3	4.0±0.2	2.0±0.1
24×4×10	24.0±0.3	4.0±0.2	10.0±0.2
25×10×28	24.8+0/-0.3	10.0+0/-0.3	28.0+0/-0.3
30×4×2	30.0±0.3	4.0±0.2	2.0±0.1
30×4×4	30.0±0.3	4.0+0.1/-0.3	4.0+0.1/-0.3
30×5×1	30.0±0.5	5.0±0.2	1.0±0.1
50×6×2	50.0+0.2/-0.8	6.0±0.3	2.0±0.1
50×23.9×9.9	50.0+0/-0.8	24.0-0.1/-0.6	10.0-0.1/-0.8
50×27.9×9.9	50.0+0/-0.8	28.0-0.1/-0.6	10.0-0.1/-0.8



形状 Shape

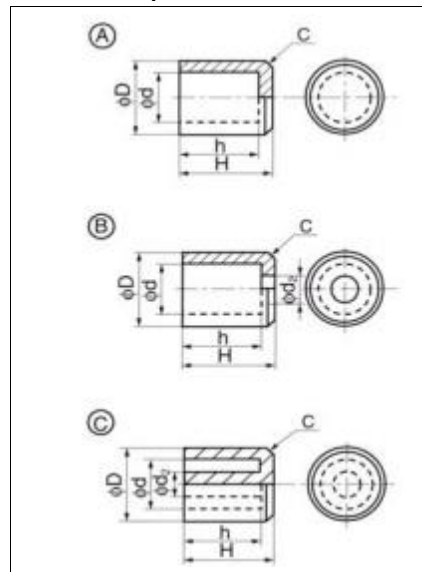

帽型磁芯的产品命名，有以下三种类型，采用了以下的命名。
Naming of pot core models

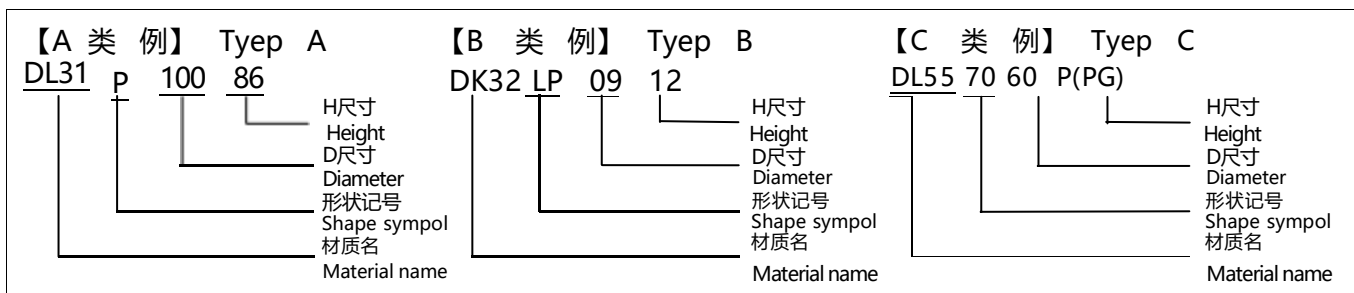

尺寸表 Dimensions (for example)

单位Unit: mm

品名	ØD	H	Ød	h	Ød2	C	种类
P6834	6.8±0.1	3.4±0.07	5.8±0.1	2.7±0.07	/	0.3	A 缺口
P7832	7.8±0.2	3.15±0.15	6.4 +0.2/-0.1	2.35±0.0.1	/	0.3	A 缺口
P8458	8.4+0.05/-0.15	5.8+0.05/-0.15	7.2+0.15/-0.05	5.0+0.15/-0.05	/	(0.1)	A
P9378	9.3±0.15	7.8±0.15	7.9±0.15	6.8±0.15	/	0.2	A
P10066	10.15+0/-0.3	6.6±0.2	8.5 +0.2/-0.1	5.5 ±0.15	/	0.3	A
7060P	7.0±0.15	6.0±0.15	5.2 +0.3/-0	4.5±0.15	2.0±0.1	0.3	C
8397P	8.3±0.15	9.7±0.2	6.7±0.15	8.4±0.2	2.8±0.1	(0.2)	C
91590P	9.15±0.2	9.0 +0.3/-0	7.0 +0.3/-0	7.6 +0.4/-0	3.2 +0/-0.2	0.3	C
LP069035	6.9±0.04	3.5±0.3	5.7±0.1	2.5±0.1	4.2±0.1	0.3	B(外研磨)
LP069037	6.9±0.03	3.7±0.1	5.7±0.1	3.1±0.1	4.2±0.1	0.3	B(外研磨)
LP069060	6.9±0.05	6.0±0.15	5.6±0.1	4.7 +0.1/-0.15	4.1±0.1	0.3	B(外研磨)
LP069060T	6.9 +0/-0.15	6.0±0.2	5.4 +0.15/-0	4.7±0.1	4.05 +0.15/-0	0.5	B
LP069061	6.9 +0/-0.15	6.1±0.2	5.4+0.2/-0	4.8±0.1	4.05 +0.2/-0	0.5	B
LP0912	9.4 +0.4/-0	12.0±0.3	7.3 +0.3/-0	10.8±0.3	4.0+0.1/-0.15	0.5	B
LP1007	10.15 +0/-0.3	6.7±0.2	8.5 +0.2/-0	5.6 +0.1/-0.2	4.2±0.2	0.5	B
LP1085	10.0±0.2	8.5 +0.15/-0.2	8.2±0.15	7.4±0.15	4.0±0.1	0.3	B
LP1110	11.5±0.15	10.0 +0.4/-0	9.5 +0/-0.3	8.5 +0.4/-0	5.0±0.12	0.5	B
LP124056	12.4±0.2	5.6±0.15	10.5 +0.3/-0	4.2±0.1	7.4±0.15	0.6±0.15	B



形状 Shapes

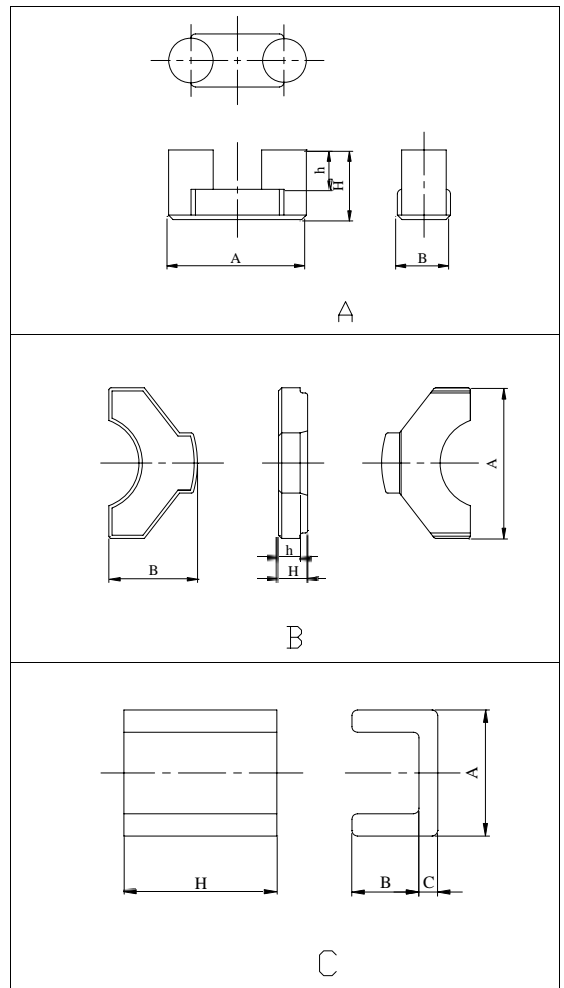

尺寸表 Dimensions(for example)

单位 Unit: mm

品名	A	B	C	H	h	种类
U-03	3.4±0.1	1.8±0.1	0.5±0.05	4.1+0/-0.2	/	C
U-09	9.1±0.2	3.5±0.2	/	4.6±0.2	2.6±0.2	A
U-09A	9.1±0.2	3.5±0.2	/	3.8±0.2	1.85±0.2	A
U-14	14+0/-0.6	8.05±0.2	/	2.7+0/-0.3	2.0±0.1	B

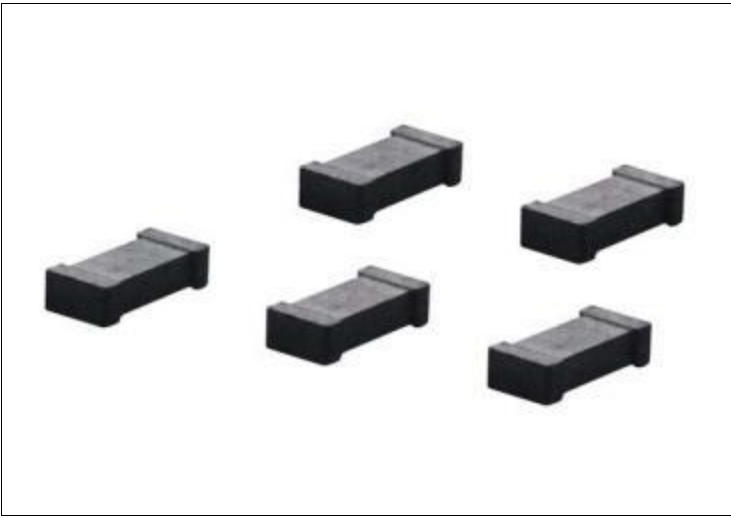

关于距型磁芯的产品命名

Naming of square drum core models

【例】 Example

DK17 HB 31 25

- A 尺寸 Height
- H 尺寸 Diameter
- 形状记号 shape symbol
- 材质名 Material name

形状 Shapes

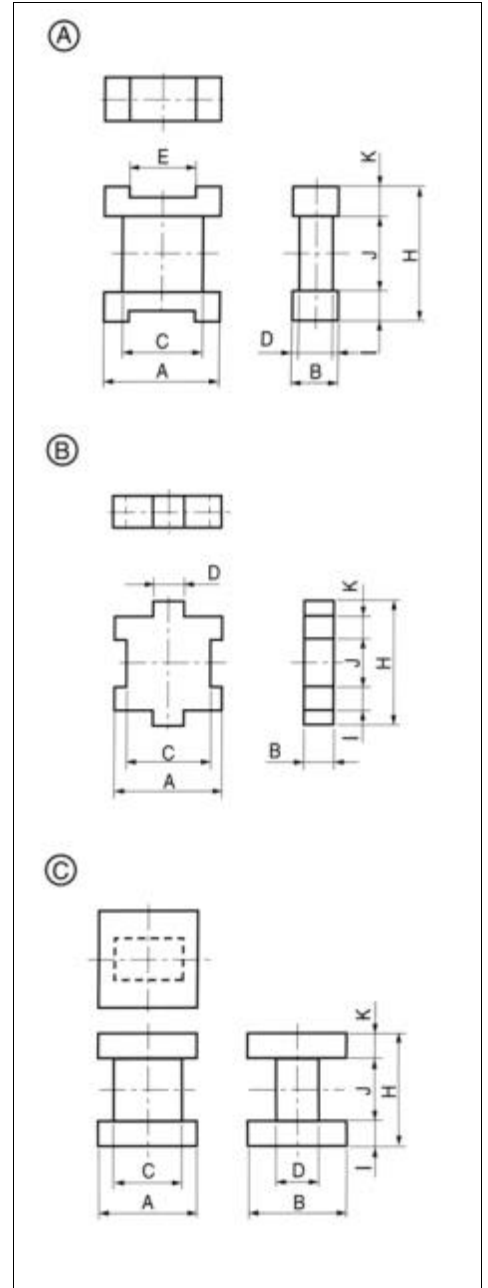

尺寸表 Dimensions(for example)

单位Unit: mm

品名	A	B	C	D	E	H	I	J	K	种类
HB2620	2.0±0.1	0.85 ⁺⁰ _{-0.1}	1.4±0.1	0.6±0.1	/	2.65±0.1	(0.35)	1.3±0.1	(0.35)	B
HB2419	1.9±0.1	1.1±0.1	(0.45)	(0.74)	0.85±0.1	2.4±0.1	(0.425)	1.55±0.1	(0.425)	A
HB3125	2.5±0.1	2.0±0.1	(1.4)	(1.2)	0.95±0.1	3.1±0.1	(0.7)	1.7±0.1	(0.7)	A
HB2013	1.25±0.05	1.25±0.05	1.0±0.30	1.0±0.03	/	2.0±0.1	0.4	1.2-0.1	0.4	C

江苏磁元电子科技有限公司

地址：江苏省兴化市陈堡工业园文林路1号

邮编：225714

网址：www.cy-mag.com.cn

JIANGSU CIYUAN ELECTRONICS TECHNOLOGY CO., LTD.

Add：Wenlin Road #1Chenbao Industrial Park Xinghua City, Jiangsu Province , PRC

Zip Code：225714

Web：www.cy-mag.com.cn